

C. PACKARD & S. STANDISH.
Fly-Traps.

No. 144,860.

.FIG. I.

Patented Nov. 25, 1873.

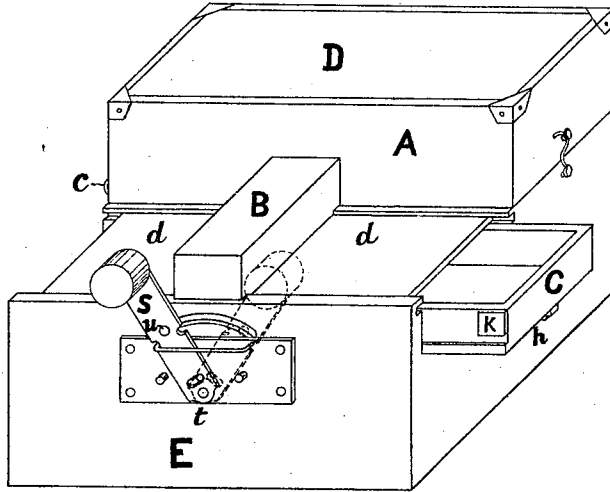

.FIG. II.

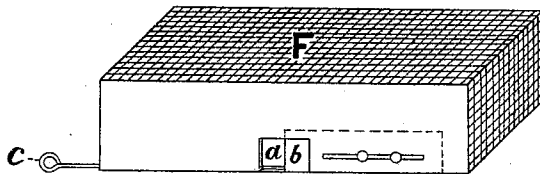

.FIG. III.

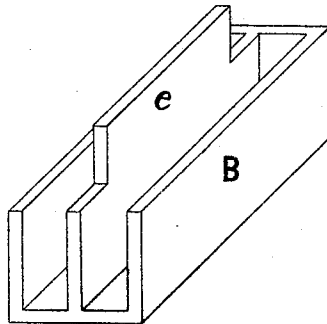

WITNESSES.

John S. Wear
Charles J. Van Alst

.INVENTOR.

Cyrus Packard
Sydney Standish
Per Ingersoll & Company
Attys

C. PACKARD & S. STANDISH.
Fly-Traps.

No. 144,860.

Patented Nov. 25, 1873.

FIG. IV.

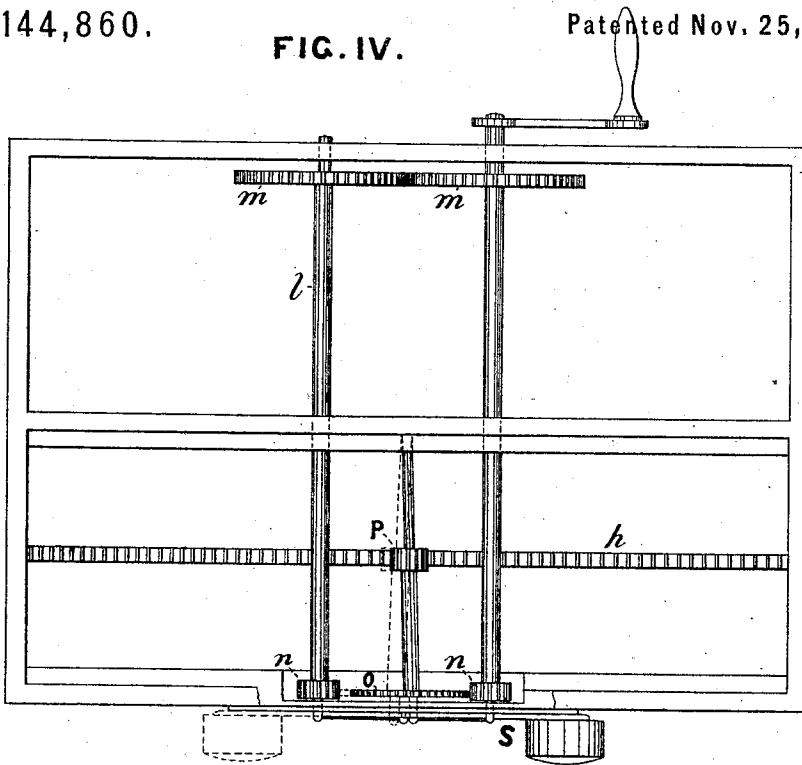
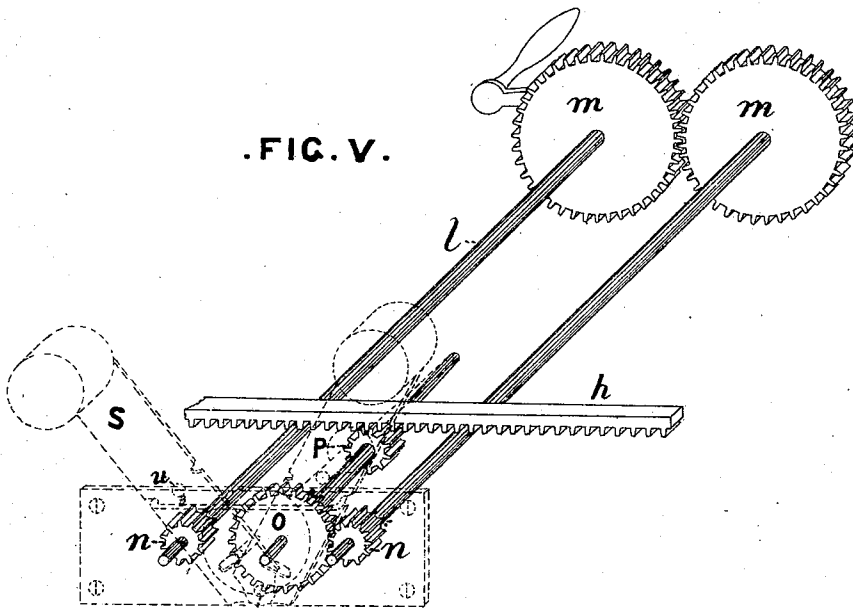

FIG. V.



WITNESSES, t
 John S. Wear
 Charles T. Hawblit

INVENTOR,
 Cyrus Packard,
 Stephen Standish
 Per Ingersoll & Co. Attys

UNITED STATES PATENT OFFICE.

CYRUS PACKARD, OF EUREKA, NEVADA, AND SYRANUS STANDISH, OF
PACHECO, CALIFORNIA.

IMPROVEMENT IN FLY-TRAPS.

Specification forming part of Letters Patent No. **144,860**, dated November 25, 1873; application filed
September 9, 1873.

To all whom it may concern:

Be it known that we, CYRUS PACKARD, of Eureka, Nevada, and SYRANUS STANDISH, of Pacheco, California, have invented a Fly-Trap, of which the following is a specification:

Our invention consists of a fly-trap so constructed as to be worked by clock gear, or any other suitable machinery; or, in places where power is used, it can be attached to the machinery and operated by the same satisfactorily, as in sugar-refineries, breweries, and distilleries.

Figure I in the accompanying drawing represents the trap as it would appear at starting. A, case, inside of which the perforated or wire receptacle for the flies is placed; D, glass cover to the case; C, reciprocating tray, into which the food is placed; K, stop on side of tray; E, lower part of case, in which the machinery is placed, also the tray C. In the lower case, and over the tray, are grooves, into which are placed two glass plates, *d d*, one on each side of the covered passage-way B.

Fig. II, perforated or wire receptacle for the flies. This receptacle is placed inside of the case A. *a'*, aperture through which the flies pass into the receptacle; *b*, sliding door, operated by the rod or handle *c'*. When the receptacle is full, pull the handle outward, and in this manner close the aperture *a'*; then, by removing the case A, the receptacle can be immersed in water, the contents shaken out, and replaced.

Fig. III, covered passage-way, through which the flies are forced into the receptacle; *e*, partition in the passage-way, reaching close to the bottom of the tray, and forming two apartments, the object being, when one end of the tray is forcing the flies through the apartment on one side, the opposite apartment, on the return of the tray, can act in the same capacity, and in this manner be more expeditious.

Figs. IV and V represent the construction of the machinery and its relative position. It will be seen that by attaching the power to

the shaft *l* the spur-wheels *m m* will revolve in opposite directions, the same motion being transmitted through their respective shafts to the pinions *n n*. The intermediate wheel *o*, meshing into the pinions *n n*, alternate. By this means the rack *h* is carried its length by the pinion P, and back. S, weighted lever, pivoted at *t*; *u*, pin in lever. When the machine is in motion, the tray C, being attached to the rack *h*, is carried its length, or the required distance, and by this means brings the flies in contact with the partition *e* in the covered passage-way B, forcing them through the aperture *a'* into the receptacle F. When the tray C has traversed the required distance, the stop K comes in contact with the pin *u*, forcing the weighted lever S over to the opposite angle. By this means the intermediate wheel *o* is transferred from mesh with the pinion *n* on the right side to the pinion *n* on the left side, and so on alternately.

Having thus described our machine and its working, what we claim as new, and wish to secure by Letters Patent, is—

1. The passage-way B and the partition *e*, in combination with the reciprocating drawer C and the wire cage F, substantially as and for the purpose specified.

2. The spur-wheels *m m* and the shafts *l l*, the pinions *n n*, intermediate wheel *o*, pinion P, rack *h*, weighted lever S, and pin *u*, in combination with the case E and the reciprocating drawer C, the whole arranged to operate substantially as and for the purpose specified.

The above specification of our invention signed by us this 28th day of August, 1873.

CYRUS PACKARD.
SYRANUS STANDISH.

Witnesses for CYRUS PACKARD:

THOMAS S. DOUGLAS,

J. H. REECE.

Witnesses for SYRANUS STANDISH:

C. A. PHILLIPS,

BENJ. LUMLEY.