

H. A. NORTON.
Railway-Switch.

No. 216,691.

Patented June 17, 1879.

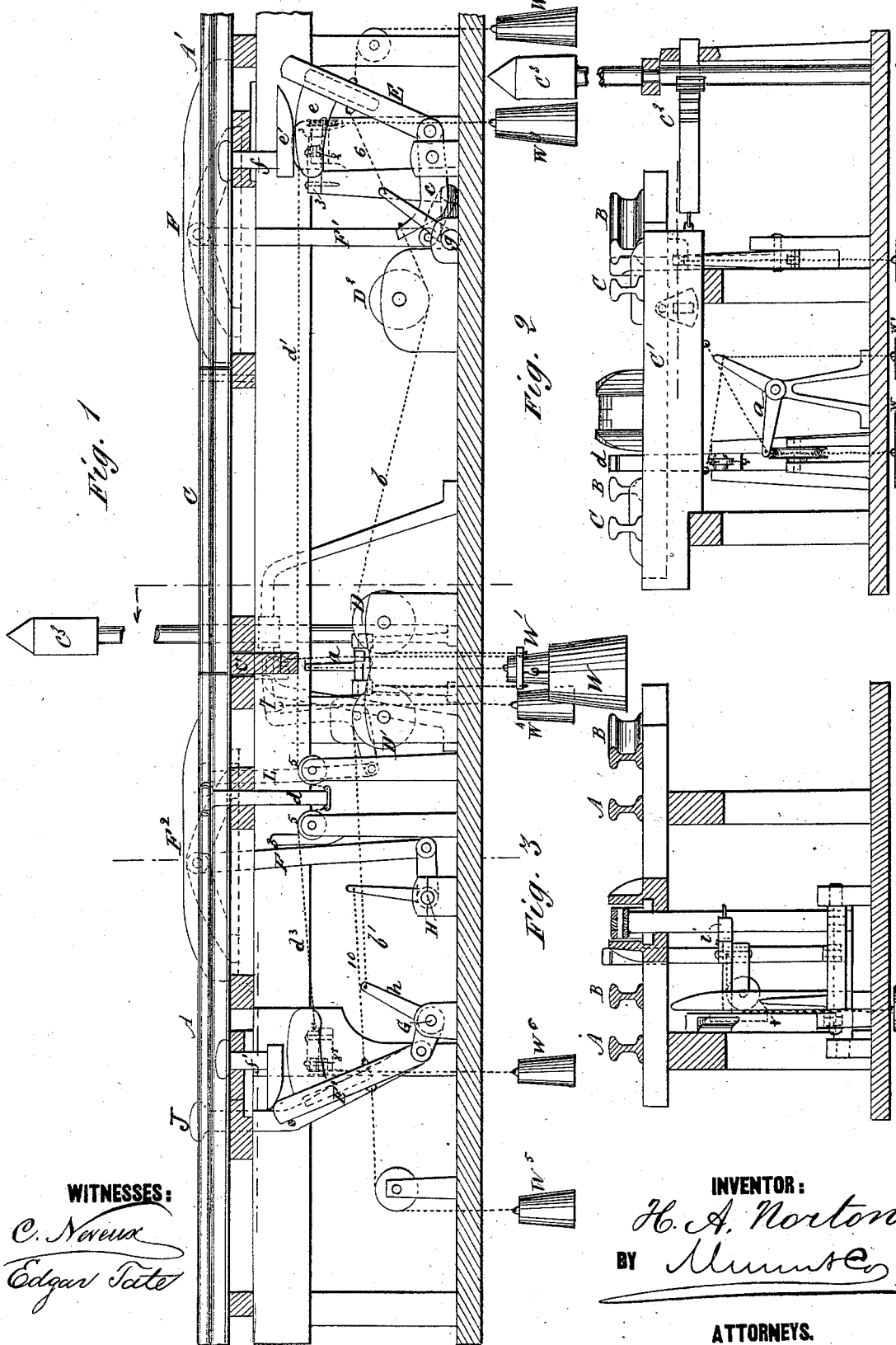

WITNESSES:
C. Novaux
Edgar Tate

INVENTOR:
H. A. Norton
 BY *Munn & Co*
 ATTORNEYS.

H. A. NORTON.
Railway-Switch.

No. 216,691.

Patented June 17, 1879.

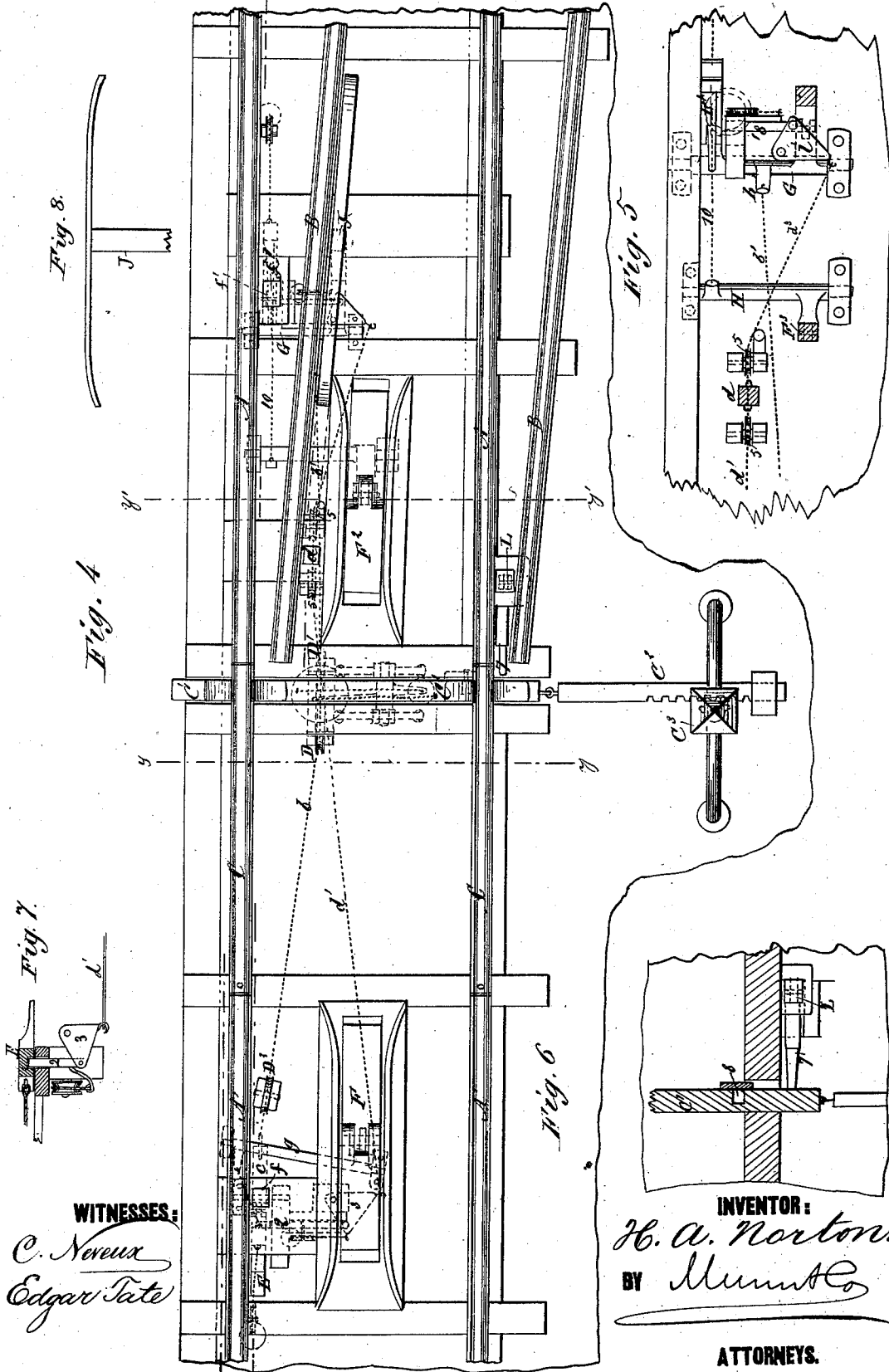

WITNESSES:
C. Neveu
Edgar Tate

INVENTOR:
H. A. Norton.
BY *Munn & Co.*

ATTORNEYS.

UNITED STATES PATENT OFFICE.

HENRY A. NORTON, OF WARD CITY, NEVADA.

IMPROVEMENT IN RAILWAY-SWITCHES.

Specification forming part of Letters Patent No. 216,691, dated June 17, 1879; application filed July 23, 1877.

To all whom it may concern:

Be it known that I, HENRY ALEXANDER NORTON, of Ward City, county of White Pine, and State of Nevada, have invented a new and Improved Railroad-Switch, of which the following is a specification.

The invention relates to that class of railroad-switches in which the switch-rails are actuated by a moving train or devices carried by the locomotive; and the invention consists in the construction and combination of parts, which will be hereinafter more fully described, and then set forth in the claims.

In the annexed drawings, Figure 1, Sheet 1, is a vertical section through the switch mechanism. Fig. 2 is a vertical transverse section taken in the plane indicated by dotted line *y*, Fig. 4. Fig. 3 is a vertical transverse section taken in the plane indicated by dotted line *y' y'*, Fig. 4. Fig. 4, Sheet 2, is a plan view of the switch and its signal-lantern. Figs. 5, 6, 7, and 8 are sectional details.

Similar letters of reference indicate corresponding parts in the several figures.

The letters A A' designate sections of main-track rails, which may be constructed and spiked down in the usual well-known manner, and B B are siding-rails, which are arranged in the relation to the main-track rails as shown in Fig. 4.

Between the ends of the rails above referred to are the switch-rail sections C C, the free ends of which are secured to a slide-bar, C'. These parts are all mounted upon trestle-work, so that a space is left below the rail-bed for the switch mechanism.

The slide-bar C' works between two ties and has a rack, C², attached to one end of it, the teeth of which engage with a half-pinion on the vertical shaft of a signal-lantern, C³, which will indicate at all times the position of the switch-rails.

Beneath the slide-bar C' is an angular rocking lever, *a*, one arm of which has a weight, W, suspended from it by a chain. The other arm of lever *a* has also a weight, W¹, which is lighter than the weight W suspended from it, and both arms are connected by chains to the slide-bar C'. By vibrating the lever *a* it

will move the switch-rails in line with the siding-rails or back again in line with the main track.

D D¹ are two grooved pulleys arranged beneath one arm of the lever *a*, over which pulleys pass two chains, *b b'*, which are attached to the weight W. When this weight W is raised the weight W¹ will move the switch-rails in line with the siding, and when weight W, being the heavier, is released it will move the switch-rails in line with the main track.

The chain *b* is carried under a pulley, D², and is attached to the upturned end of a lever, *c*, which is pivoted to a bar, E, having a curved horn, *e*, formed on it, on which a shoe, *e'*, rests. Shoe *e'* is secured to a push-rod, *f*, the upper end or head of which is arranged in close relation to one of the rails, A', of the main line, so that when the end of bar E is brought beneath the shoe *e'* the wheels of a car will press down the bar E, raise the weight W, and move the switch-rails in line with the siding.

The bar E is locked in the upright position by a latch, 2, and when this latch is withdrawn a weight, W², will move back the bar E and allow the push-rod *f* to drop out of the way of the wheels of a passing train.

The latch 2 is pivoted to a vibrating segment, 3, and is shot into a groove in bar E by the action of a weight, W³. The latch 2 is retracted, so as to release bar E by the wheels of a car, depressing a push-rod, *d*, arranged in close relation to one of the stationary siding-rails, which rod is connected to the segment 3 by a chain, *d'*, that passes over one of twin pulleys 5. (Shown in Fig. 1.)

F designates a saddle, which is a toggle-lever, arranged between guides and between the rails A'. This saddle has a push-bar, F¹, pivoted to it, the lower end of which is pivoted to an arm on a rock-shaft, *g*, (shown placed obliquely to the line of track,) and to another arm on this rock-shaft the bar E is connected by a short chain, 6.

By depressing the saddle at the middle of its length, the bar E will be brought under the push-rod *f*, and this rod raised so that it will be struck by the wheels of a passing

train, thereby moving the switch-rails into line with the siding. When the switch-rails are thus adjusted they are securely held by means of a latch, 7, which is caused by a weight, W^4 , to enter a recess, 8, in the slide-bar C^1 .

The latch 7 is pivoted to a push-rod, L, which is arranged in close relation to one of the siding-rails B, so that it will be struck by the wheels of a car on this rail and the latch disengaged from the slide-bar, allowing weight W to move the switch-rail in line with the main-track rails as soon as the wheels of a passing train have left the movable rails.

The chain b' is carried from the weight W over pulley D^1 , and is attached to an arm, h , on a rock-shaft, G. This shaft G has a bar, E' , pivoted to it, which works beneath a push-rod, f' , precisely as described for the bar E on the opposite side of the switch. The bar E' is moved from beneath the push-rod f' , when it is released from a latch, S' , by means of a weight, W^5 , and it is moved beneath the push-rod f' by depressing a saddle, F^2 . The saddle F^2 has a push-bar, F^3 , pivoted to it, which is also pivoted to an arm of a rock-shaft, H, and another arm on this shaft is connected by a chain, 10, to the bar E' .

The latch S' is pivoted to a segment, i , which is free to vibrate, and which is connected by a chain, d^3 , to the push-rod d for releasing the bar E' when the rod d is pressed by a wheel running over it. A weight, W^6 , causes the latch S' to engage with the bar E' .

Thus far it will be seen that the mechanism for operating the switch is substantially the same at both ends of the switch.

J designates a push-bar, which is pivoted to an arm on the rock-shaft G, and which is so arranged that it will be depressed by the wheels of a car on the siding, and the switch-rails thus actuated. A long cap, Figs. 4 and 8, is attached to bar J, and runs parallel with the siding-rail which is next to the push-bar J. When the locomotive-wheels pass over the cap the push-bar J will be held down until the whole train shall have passed. This cap is made of such length that the hindmost wheels of a car will always be on it before the front wheels have passed.

There will be a lever of a suitable description placed under the cow-catcher, controlled by the engineer, who can at will depress one or the other of the saddles and actuate the switch while the train is in motion.

The general operation of the apparatus is as follows: Suppose the left hand of Fig. 4 to be the east, and the right hand west, and that a train is approaching from the east. (The right-hand end of Fig. 1 corresponds to the east.) When the locomotive reaches the lever F the engineer strikes the latter with the lever attached to the truck, and depresses it, thus rocking the shaft g , and causing wire 6 to draw the bar E forward to a vertical position beneath shoe e' . Such upward movement

of the shoe carries bar f up into position to be struck by the train-wheels. It is therefore depressed as the train passes on, and the bar E is thereby forced down, which tilts lever C, and, by the tension thus exerted on wire b , raises the large weight, W, and allows the smaller weight, W^1 , to rock the shaft a and slide C^1 to the right, thus bringing the switch-rails C into line with the siding-rails B, in which position the switch-rails are at once locked automatically by the catch 7. The train then passes onto the siding B, and in doing so the bar d is depressed by the wheels, and the catch 2 drawn back by tension on wire d^1 , Fig. 7 so that the weight W^1 is allowed to draw the bar E back to its original inclined position, Fig. 1. The train-wheels also depress the bar L, Fig. 4, and thus draw back catch 7 and release switch-bar C^1 , so that as the wheels of the last car leave the switch-rails the latter are moved back to the original position into line with the main track.

To make a "flying switch," when a train approaches from the same direction as above—namely, the east—the locomotive is allowed to pass over the switch-rails, and the engineer strikes lever F^2 with the lever attached to the engine, and depresses it, thus raising bar E' , which is, in turn, depressed by the train-wheels, forcing down bar f' , thus rocking shaft G, tilting arm h , and raising weight W by tension on wire b , and shifting the switch-rails in line with siding-rails; and so soon as the switch-rails C^1 are relieved of pressure by passage of the train beyond them they are thrown into line with the main-track rails A, as before described.

When a train approaches from the west on the main line A, and it is desired to back on the siding B, the engineer strikes lever F, and thus throws the switch-rails C to the right, as before described; but, of course, such movement of the switch-rails does not occur until the last car has passed over them, and thus left them free of pressure.

When a train approaches on the siding passing eastward, the train-wheels strike and depress bar J, thus tilting the rock-shaft G' , to which the bar J is pivoted, and, by tension of wire h , raising weight W, and shifting the switch-rails into line with the siding B.

Having thus fully described my invention, I claim as new and desire to secure by Letters Patent—

1. The combination of the push-bar L, the horizontally-sliding latch 7, and the weight W^4 with the slide-bar C^1 , having an opening, 8, and the switch-rails C, as and for the purpose set forth.

2. In combination with the slide-bar C^1 , the lever a , connected to this bar by crossed chains, and acted on by weights W W^1 , substantially as described.

3. The saddle F, push-rod F^1 , and rock-shaft g , connected by a chain, 6, to a bar, E, having a horn on it, in combination with weights W^2

W, shoe *e*, and push-rod *f*, arranged to operate a switch, substantially as described.

4. The latch 2, combined with the vibrating bar E, chain *d*¹, weight W³, and push-rod *d*, substantially as described.

5. Push-rod J, shaft G, chain 10, shaft H, push-rod F³, and saddle F², in combination

with the weight W¹, substantially as described.

HENRY A. NORTON.

Witnesses:

W. B. MORSE,
J. CHARLETON.