

No. 853,244.

PATENTED MAY 14, 1907.

W. E. INGRAM.
WRENCH.

APPLICATION FILED AUG. 8, 1906.

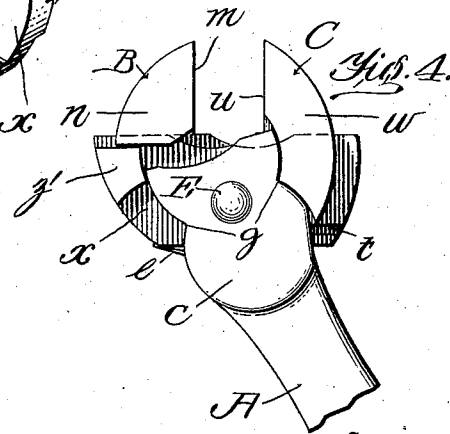
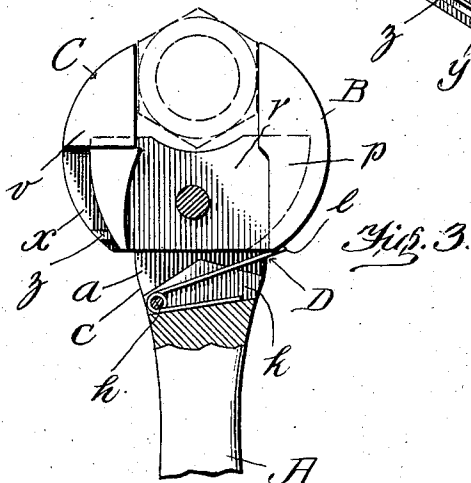
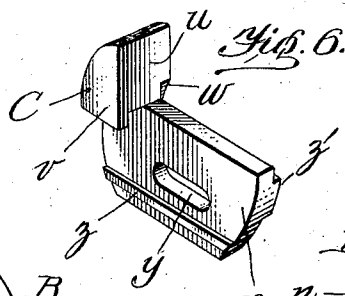
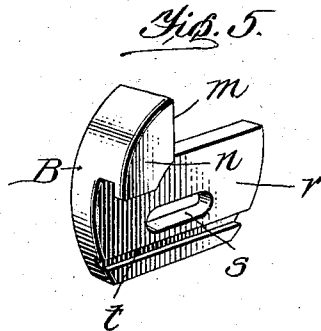
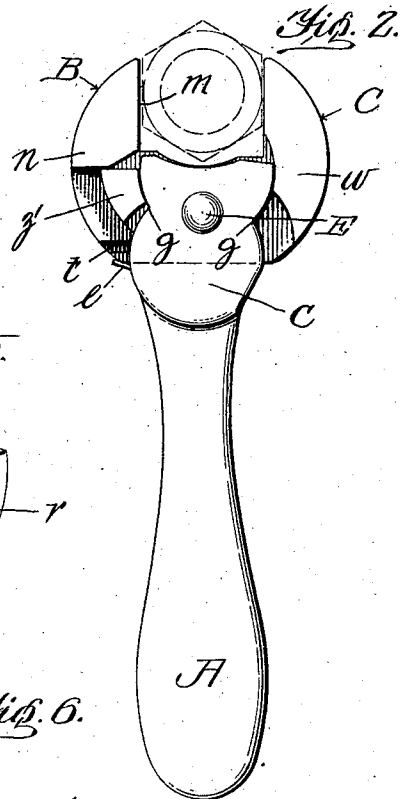
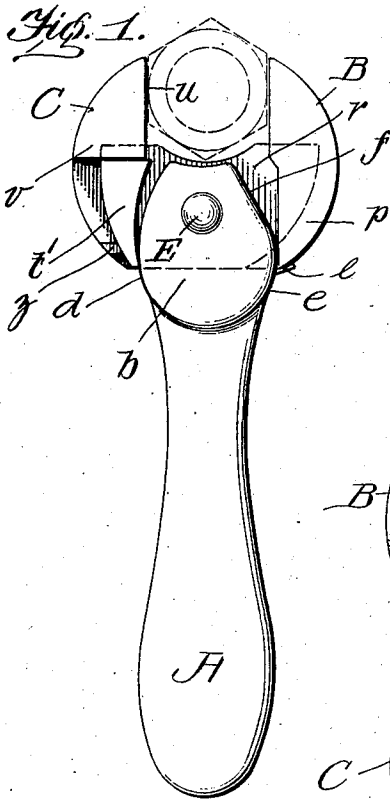

Witnesses

O. W. Holmes
Thos. E. Turpin

By

W. E. Ingram
James Shubert
Inventor
Attorney

UNITED STATES PATENT OFFICE.

WESLEY EDWARD INGRAM, OF TONOPAH, NEVADA.

WRENCH.

No. 853,244.

Specification of Letters Patent.

Patented May 14, 1907.

Application filed August 8, 1906. Serial No. 329,728.

To all whom it may concern:

Be it known that I, WESLEY EDWARD INGRAM, a citizen of the United States, residing at Tonopah, in the county of Nye and State of Nevada, have invented new and useful Improvements in Wrenches, of which the following is a specification.

My invention pertains to wrenches; and it contemplates the provision of a wrench for turning nuts, pipes and other articles, and one embodying such a construction that its jaws will automatically accommodate themselves to articles of various sizes, and will take secure hold of an article when the wrench is moved in one direction, and slip freely over the article when the wrench is moved in the opposite direction, this latter in order to facilitate the taking of a fresh hold and in that way expedite the turning of a nut or pipe in one direction or the other.

Other advantageous characteristics of my wrench will be fully understood from the following description and claims when the same are read in connection with the accompanying drawings, forming part of this specification, in which.

Figure 1 is a side elevation of the wrench constituting the present and preferred embodiment of my invention, as the same appears when properly positioned on a nut. Fig. 2 is a similar view showing the opposite side of the wrench. Fig. 3 is a detail view with the parts in the same position as in Fig. 1 but with one side wall of the bifurcation in the handle broken away to illustrate the arrangement of the spring. Fig. 4 is a detail view of the side shown in Fig. 2, but illustrating the jaws and handle in their normal relative positions. Figs. 5 and 6 are perspective views of the sliding jaws of the wrench.

Similar letters designate corresponding parts in all of the views of the drawings, referring to which:

A is the handle of my novel wrench which is preferably formed of one piece of metal suitable to the purpose. The said handle is bifurcated at one end, as indicated by *a* in Fig. 3, and the side walls *b* and *c* of the said bifurcation are best shown in Figs. 1 and 2, respectively. The upper or outer ends of the walls *b* and *c* are dished as shown in order not to interfere with the reception of large nuts between the sliding jaws, and the wall *b* is generally shaped as shown—that is, it has a

convex left hand edge *d* and a right hand edge the lower part *e* of which is convex while the upper part *f* declines inward. The wall *c* has notches *g* in its edges and convex edge portions above and below said notches as clearly shown in Figs. 2 and 4.

B is one of the sliding jaws of the wrench. C is the other sliding jaw, and D is the spring which is secured by a transverse pin *h* in a recess *k* below the bifurcation *a* and has an upper arm *l* arranged to bear directly against the lower or inner edge of the jaw B.

As will be seen by reference to Figs. 2 and 5, the jaw B has a face *m* arranged to engage the nut, pipe or other article to be turned, an overhanging portion *n* at one side, a lateral projection *p* at its opposite side, and a shank *r* disposed at a right angle to the face *m* and in which is a longitudinal slot *s* and a longitudinal groove *t*. Said jaw B also has a lateral projection *t'* on its shank *r* at the same side of the jaw as the projection *p*. The jaw C has a face *u*, an overhanging portion *v* at one side, a lateral projection *w* at the opposite side, and a shank *x*, disposed at a right angle to the face *u* and provided with a longitudinal slot *y* and tongue *z*. Said shank *x* is further provided with a lateral projection *z'* which is arranged on the same side of jaw C as the lateral projection *w*, Figs. 2 and 6.

In assembling the parts of the wrench, the shanks of the jaws B and C are arranged side by side between the walls of the bifurcation *a*, and with the tongue *z* of shank *x* in the groove *t* of shank *r*, and also with shank *x* under the overhanging portion *n* of jaw B and the shank *r* under the overhanging portion *v* of jaw C. With the parts thus arranged, the arm *l* of spring D bears against the lower edge of the shank on jaw B, while the slots *s* and *y* of the jaws B and C, respectively, are registered to receive a pin E through the medium of which the jaws are secured in the handle in such manner that the jaws are free to move with respect to the handle.

The parts of my novel wrench normally rest in the positions shown in Fig. 4, and it will be apparent that when the wrench is applied to a nut as in Fig. 2, the jaws B and C will move apart to receive the nut. From this it follows that the wrench is capable of being easily applied to nuts or other articles of various sizes within the limit to which the jaws can be opened and closed. It will also

be apparent that when the wrench is applied as stated and the handle A is moved in the direction indicated by arrow in Fig. 1 the jaws B and C will take secure hold of the nut and cause the same to move with the handle, while when the handle is moved in the direction opposite to that indicated by the arrow the jaws will slip over the nut. This latter is obviously advantageous since it permits of the wrench being freshly positioned on the nut with facility and in that way expedites turning of the nut to the point desired.

When the wrench is applied to the nut as shown in Fig. 1 the nut may obviously be quickly and easily turned toward the right, while when the wrench is applied as shown in Fig. 2 the nut may be turned toward the left or off a bolt with equal facility.

In addition to the advantages hereinbefore ascribed to my novel wrench, it will be noted that the wrench is simple and compact in construction and is well adapted to withstand the rough usage to which wrenches are ordinarily subjected.

I have specifically described the construction and relative arrangement of the parts embraced in the present and preferred embodiment of my invention in order to impart a full, clear and exact understanding of the said embodiment. I do not desire, however, to be understood as confining myself to the said specific construction and relative arrangement of parts as such changes or modifications may be made in practice as fairly fall within the scope of my invention as claimed.

Having described my invention, what I claim and desire to secure by Letters-Patent, is:

1. In a wrench, the combination of a bifurcated handle, and slidable jaws connected with the handle and movable toward and from each other in the bifurcation thereof; each of said jaws having lapped shanks arranged in the bifurcation of the handle, and also having portions arranged to engage opposite edges of one wall of said bifurcation in the handle, whereby when the handle is moved in one direction the jaws will be moved apart and when the handle is moved

in the other direction the jaws will be moved toward each other.

2. In a wrench, the combination of a bifurcated handle, slidable jaws connected with the handle and movable toward and from each other in the bifurcation thereof; each of said jaws having lapped shanks arranged in the bifurcation of the handle and also having portions arranged to engage opposite edges of one wall of said bifurcation in the handle, whereby when the handle is moved in one direction the jaws will be moved apart and when the handle is moved in the other direction the jaws will be moved toward each other, and a spring carried by the handle and arranged to engage one jaw and tending to move said jaw toward the other jaw.

3. In a wrench, the combination of a bifurcated handle, slidable jaws having lapped and slotted shanks arranged in the bifurcation of the handle and also having a tongue and a groove arranged one in the other; each of said jaws also having lateral projections disposed at opposite sides of one side wall of the bifurcation in the handle, and a pin extending through the side walls of the bifurcation in the handle and the slots in the jaw shanks.

4. In a wrench, the combination of a bifurcated handle, slidable jaws having lapped and slotted shanks arranged in the bifurcation of the handle and also having a tongue and a groove arranged one in the other; each of said jaws also having lateral projections disposed at opposite sides of one side wall of the bifurcation in the handle, a pin extending through the side walls of the bifurcation in the handle and the slots in the jaw shanks, and a spring carried by the handle and having an arm bearing against the inner edge of one jaw shank.

In testimony whereof I have hereunto set my hand in presence of two subscribing witnesses.

WESLEY EDWARD INGRAM.

Witnesses:

F. J. CONLEY,
E. B. CUSHMAN.