

J. T. TOLLESON & C. JAMES.  
 WATER MOTOR.  
 APPLICATION FILED-SEPT. 13, 1910.

997,719.

Patented July 11, 1911.

2 SHEETS-SHEET 1.

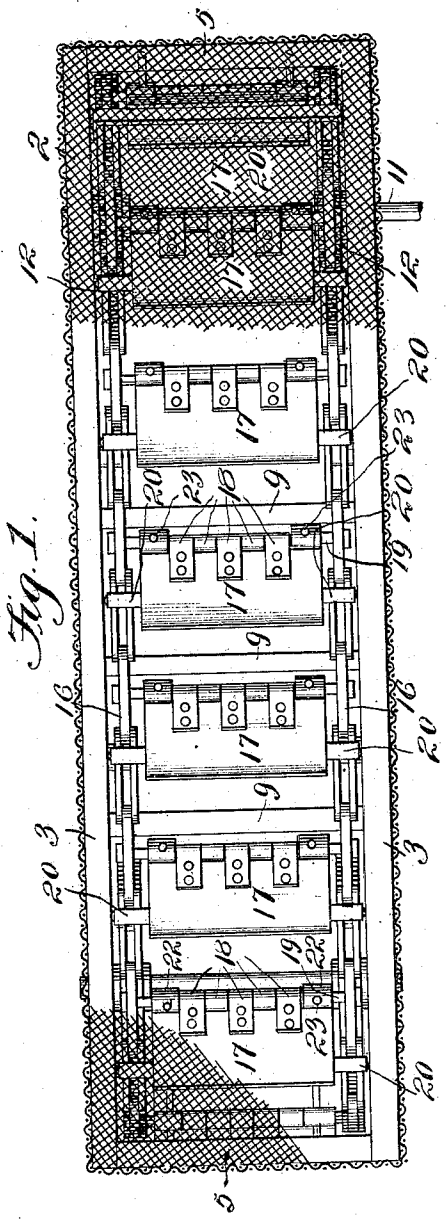

Fig. 1.

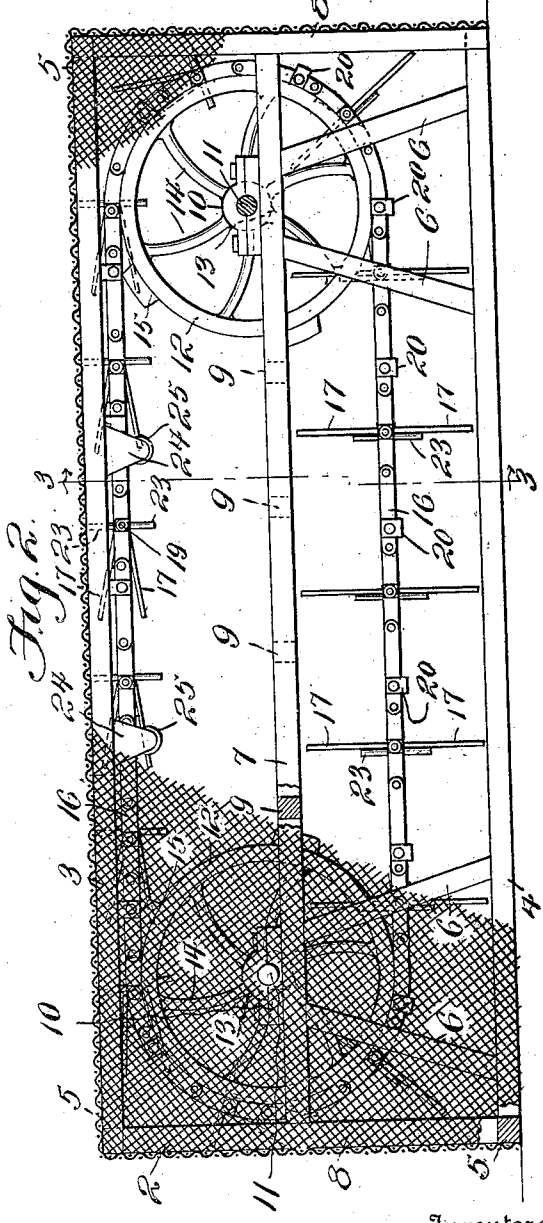

Fig. 2.

Witnesses  
*J. L. Wright*  
*H. O. Danks*

Inventors  
*John T. Tolleson*  
*Clark James*  
 By *Victor J. Evans,*  
 Attorney

J. T. TOLLESON & C. JAMES.  
 WATER MOTOR.  
 APPLICATION FILED SEPT. 13, 1910.

997,719.

Patented July 11, 1911.

2 SHEETS—SHEET 2.

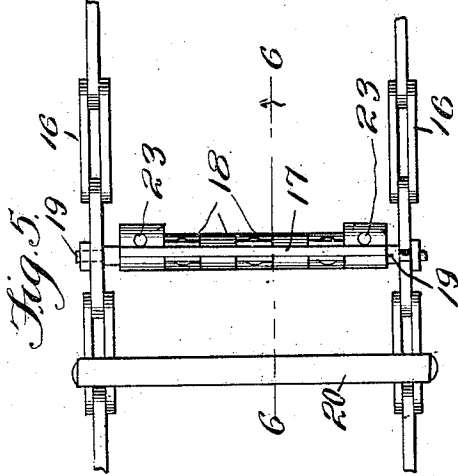
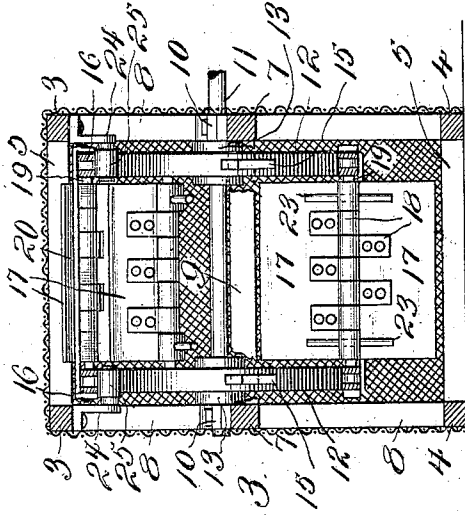
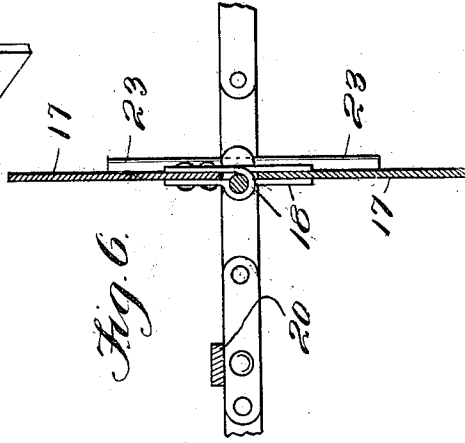
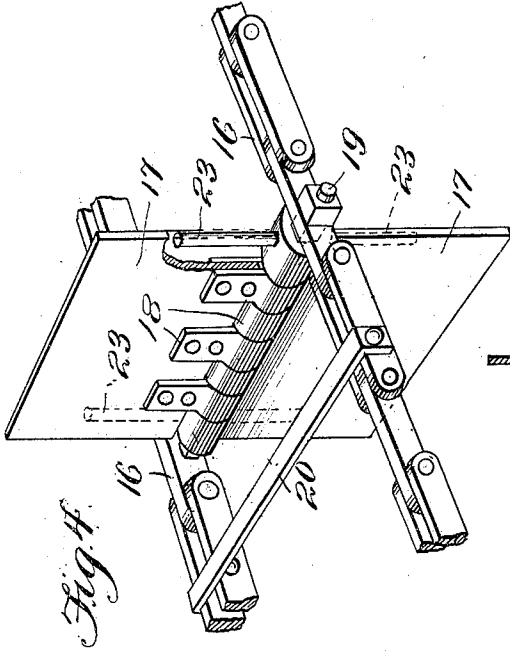

Witnesses

*J. L. Wright*  
*H. O. Parker*

Inventors  
*John I. Tolleson*  
*Clark James*

By *Victor J. Evans,*  
 Attorney

# UNITED STATES PATENT OFFICE.

JOHN T. TOLLESON AND CLARK JAMES, OF MANHATTAN, NEVADA.

WATER-MOTOR.

997,719.

Specification of Letters Patent.

Patented July 11, 1911.

Application filed September 13, 1910. Serial No. 581,771.

*To all whom it may concern:*

Be it known that we, JOHN T. TOLLESON and CLARK JAMES, citizens of the United States, residing at Manhattan, in the county of Nye and State of Nevada, have invented new and useful Improvements in Water-Motors, of which the following is a specification.

The invention relates to a water motor, and more particularly to the class of current motors.

The primary object of the invention is the provision of a motor of this character in which the force of water currents will be utilized for driving machinery or the like, thus minimizing the expense in the running thereof.

Another object of the invention is the provision of a water motor of this character in which the paddles or wings when submerged below the surface of a body of water will automatically face the current to receive the impact thereof, whereby the force of the current may be utilized for motive power in driving machinery, or other mechanism or apparatus.

A further object of the invention is the provision of a water motor in which the propeller wings thereof are so mounted as to automatically open when moving with the current and close on reverse movement, so that an even and uninterrupted movement from the water current will be imparted to the motor, whereby it may be advantageously utilized for motive power for driving heavy or light machinery.

A still further object of the invention is the provision of a water motor of this character which is simple of construction, thoroughly reliable and efficient in operation, and inexpensive in manufacture.

A still further object of the invention is the provision of a motor that will run equally as well when either partially or entirely submerged in water.

A still further object of the invention is to construct a motor that will run in either high or low tide, so that the full force of the current may be utilized for driving machinery or the like.

With these and other objects in view, the

invention consists in the construction, combination and arrangement of parts, as will be hereinafter more fully described, pointed out in the claims hereunto appended, and illustrated in the accompanying drawings.

In the drawings: Figure 1 is a top plan view of a motor constructed in accordance with the invention. Fig. 2 is a side elevation thereof. Fig. 3 is a vertical transverse sectional view on the line 3—3 of Fig. 1. Fig. 4 is a fragmentary perspective view of the endless chain with the wings attached thereto. Fig. 5 is an enlarged top plan view thereof. Fig. 6 is a vertical transverse sectional view on the line 6—6 of Fig. 5.

Similar reference characters indicate corresponding parts throughout the several views of the drawings.

Referring to the drawings by numerals, 2 designates generally a rectangular-shaped skeleton frame preferably of the construction here shown, although it may be of any other desirable construction, comprising spaced horizontally arranged upper and lower longitudinal side beams 3 and 4, respectively, the same being connected by cross end beams 5 in any suitable manner, and rising from these lower side beams 4 near opposite ends of the said frame 2 are upwardly converging uprights or posts 6, the same being connected in any suitable manner at their upper ends to intermediate longitudinal side beams or brace bars 7, the latter being connected at their ends to vertical standards or corner posts 8. These standards or corner posts 8 are fixed to the upper and lower side beams 3 and 4 at the ends of the frame. Fixed to the intermediate side beams 7 at intervals are transverse brace bars 9 serving to strengthen the frame.

Between the upwardly converging uprights or posts 6 and fixed to the intermediate side beams 7 are bearings 10, in which are journaled the ends of horizontally disposed rotatable shafts 11, to which latter are fixed spaced vertically arranged sprocket wheels 12 comprising hubs 13 from which extend outwardly diverging curved spokes 14, the latter at their outer ends engaging with a toothed rim 15, and over these wheels are trained sprocket chains 16, each includ-

ing a series of pivotally connected links of the usual construction, the links being joined to form the endless chain.

Supported between the endless chains 16 are spaced blades or wings to receive the impact of water currents in a stream in a manner as will be hereinafter more fully described. Each blade or wing comprises a rectangular shaped plate 17, the plates being connected at their inner edges by means of strap hinges 18 to cross rods 19 which have their ends fixed to adjacent links of the spaced chains 16, the said rods being spaced from each other on the chain.

Fastened to the links of the chains 16 are spacer bars 20, the latter being disposed in the path of movement of the plates 17 when swinging toward each other, so as to prevent the said blades from contacting with each other, and sustaining them in slightly open relation when moving in a reverse direction to the course of the current, thereby feathering the latter so as not to impede the movement of the motor. It is evident that should the blades 17 when moved toward each other contact, the same would be stuck together so that it would be impossible for them to automatically open or assume a position for receiving the impact force of a water current, therefore, the said bars 20 will obviate this during the operation of the motor.

Carried by suitable sleeves surrounding the cross rods 19 are stop fingers or arms 23, the same being positioned relatively to the blades or wings 17, so as to limit the opening movement, or in other words, the separation thereof outwardly with respect to each other. The blades or wings when in open position will strike the arms or stop fingers, so that the said blades or wings will be held in alinement with each other to face the water currents, so as to receive the impact thereof for moving the chains 16 in the direction of flow of the current thereby rotating the sprocket wheels and simultaneously the shafts 11 supporting the same, whereby the force of the water current may be utilized through the medium of the said shafts 11 in driving the machinery of other mechanism, as may be found expedient or desirable.

The frame 2 of the motor is positioned within the body of water so that the sprocket wheels will be submerged therein substantially one-half or all of their diameter, so that the blades or wings 17 carried by the sprocket chains 16 will open and close automatically by the impact from the water currents for the operation of the motor.

Depending from the upper side beams 3 of the frame are hangers or bearings 24 in which are journaled guide rollers 25 over which are adapted to travel the chains 16 so

as to prevent the latter from sagging during the operation thereof over the sprocket wheels, thus obviating binding of the chains upon the said wheels, whereby the free and easy rotary movement of the wheels will not be impeded during the operation of motor. It will be noted that the blades will close when going against the current and assume a substantially closed position, or in other words, the said blades will swing toward each other against the bars 20, so that the water current thereby will be shed from the blades as they go against the current, while those blades going with the current open and receive the impact of the current.

Connected with the skeleton frame 2 of the motor is a wire netting 26, the latter being for the purpose of preventing floating objects contained within the water from gaining access to the motor within the frame, thus avoiding any possible injury to the blades or the adjunct parts of the said motor.

What is claimed is:

1. The herein described motor, comprising an elongated foraminous frame having spaced parallel side beams at the opposite side walls thereof, bearings secured to said beams near opposite ends of the frame, journals rotatably supported in said bearings, spaced parallel sprocket wheels fixed to said journals, endless sprocket chains trained over the sprocket wheels, spaced transverse rods carried by said chains and connecting the same in a unit, foldable blades having looped hinge connections with each rod, collars disposed between the chains and the outer looped hinge connections of the blades and fixedly surrounding the rods, pins passed through and secured to the said collars to limit and hold the blades in alinement with each other when swung outwardly, and means connected to the chains in the path of inward movement of the blades for preventing the contacting of the same when in closed position.

2. The herein described motor, comprising an elongated foraminous frame having spaced parallel side beams at the opposite side walls thereof, bearings secured to said beams near opposite ends of the frame, journals rotatably supported in said bearings, spaced parallel sprocket wheels fixed to said journals, endless sprocket chains trained over the sprocket wheels, spaced transverse rods carried by said chains and connecting the same in a unit, foldable blades having looped hinge connections with each rod, collars disposed between the chains and the outer looped hinge connections of the blades and fixedly surrounding the rods, pins passed through and secured to the said collars to limit and hold the blades in alinement with each other when swung out-

wardly, means connected to the chains in  
the path of inward movement of the blades  
for preventing the contacting of the same  
when in closed position, hangers secured to  
5 and depending from the top of the frame,  
and friction rollers journaled on the hang-  
ers and engaging the said chains for pre-  
venting sagging thereof when in motion.

In testimony whereof we affix our signa-  
tures in presence of two witnesses.

JOHN T. TOLLESON.  
CLARK JAMES.

Witnesses:

F. KETELKUT,  
H. DAUBLE.