

Sept. 17, 1929.

A. B. HECTOR

1,728,860

PRODUCING COLOR MUSIC AND OTHER SPECTACULAR LUMINOUS EFFECTS

Filed July 7, 1927

4 Sheets-Sheet 1

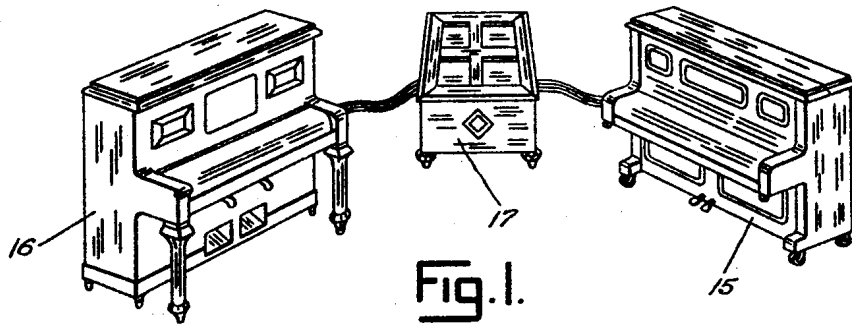
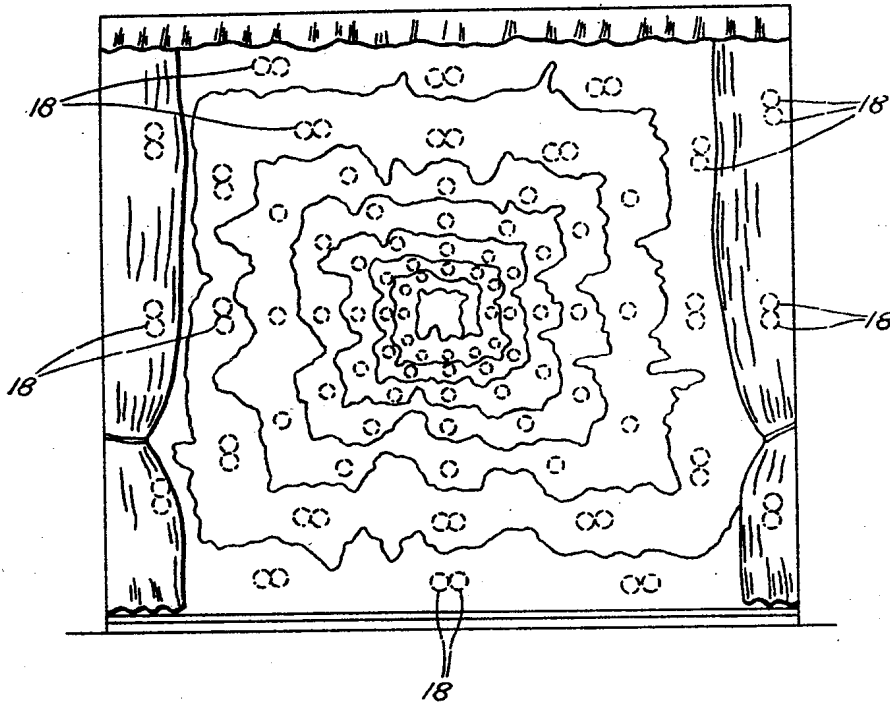

Fig. 1.

Inventor:  
Alexander Burnett Hector.

BY *James L. Norris*,  
Attorney.

Sept. 17, 1929.

A. B. HECTOR

1,728,860

PRODUCING COLOR MUSIC AND OTHER SPECTACULAR LUMINOUS EFFECTS

Filed July 7, 1927

4 Sheets-Sheet 2

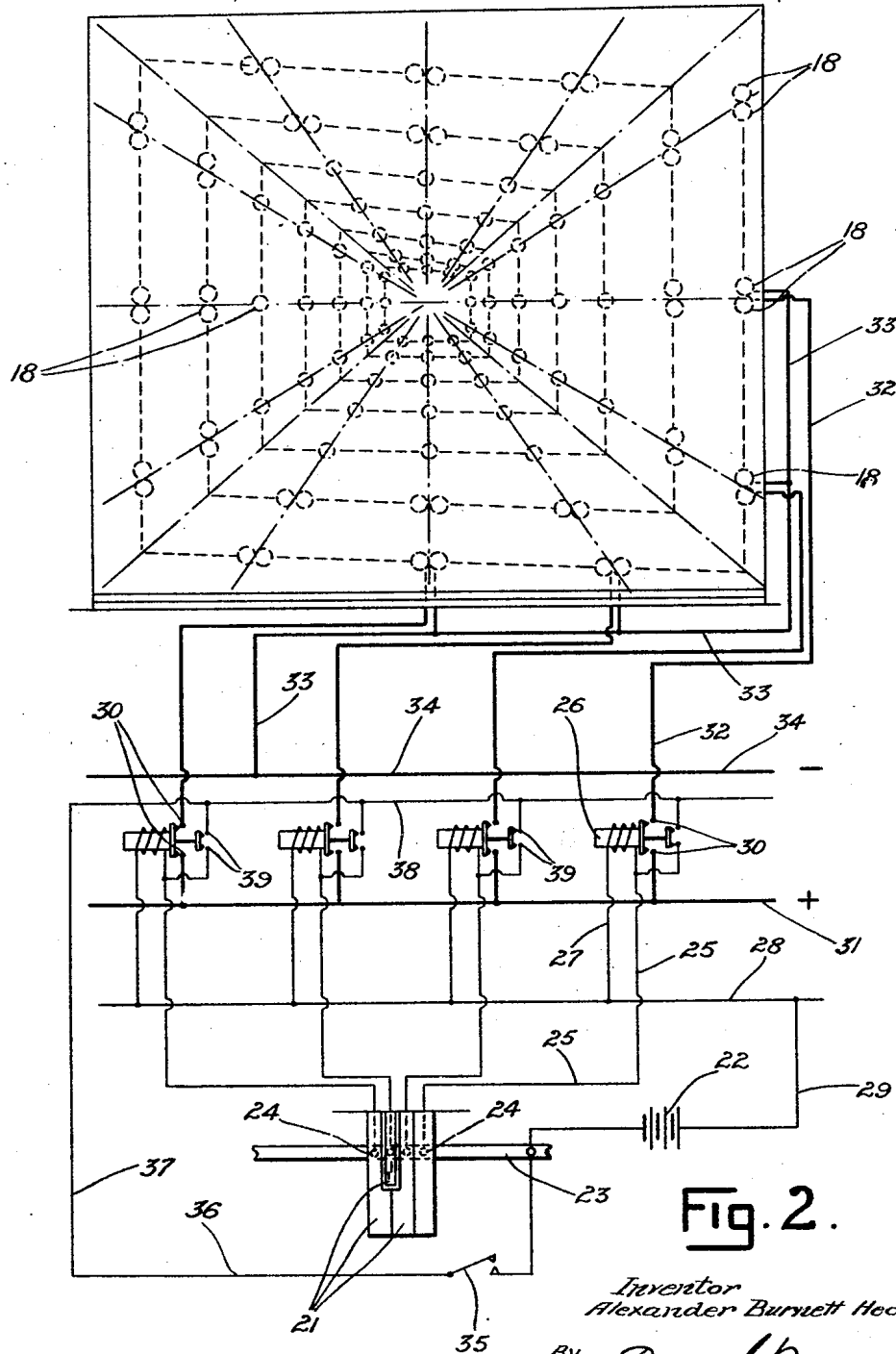

Fig. 2.

Inventor  
Alexander Burnett Hector

By *Amos L. Patton*

Attorney.

Sept. 17, 1929.

A. B. HECTOR

1,728,860

PRODUCING COLOR MUSIC AND OTHER SPECTACULAR LUMINOUS EFFECTS

Filed July 7, 1927

4 Sheets-Sheet 3

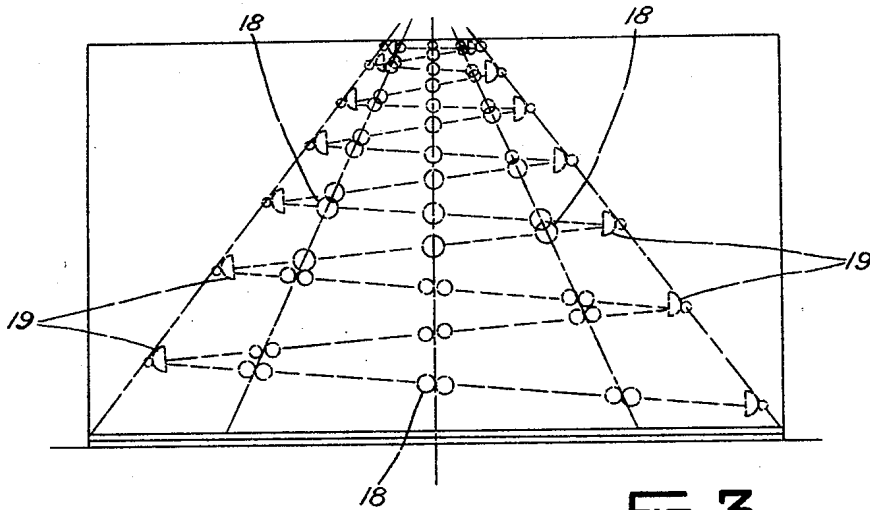
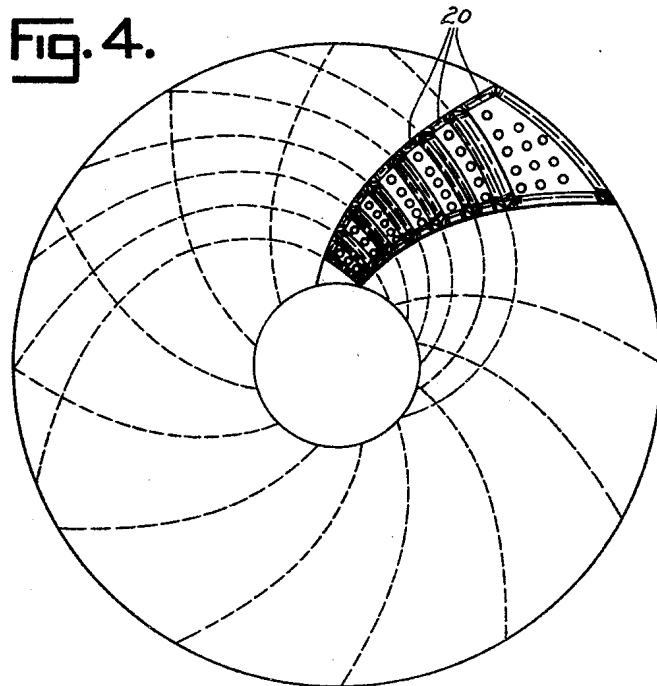

Fig. 3.

Fig. 4.



Inventor:  
Alexander Burnett Hector.  
By *James L. Perry*  
Attorney.

Sept. 17, 1929.

A. B. HECTOR

1,728,860

PRODUCING COLOR MUSIC AND OTHER SPECTACULAR LUMINOUS EFFECTS

Filed July 7, 1927

4 Sheets-Sheet 4

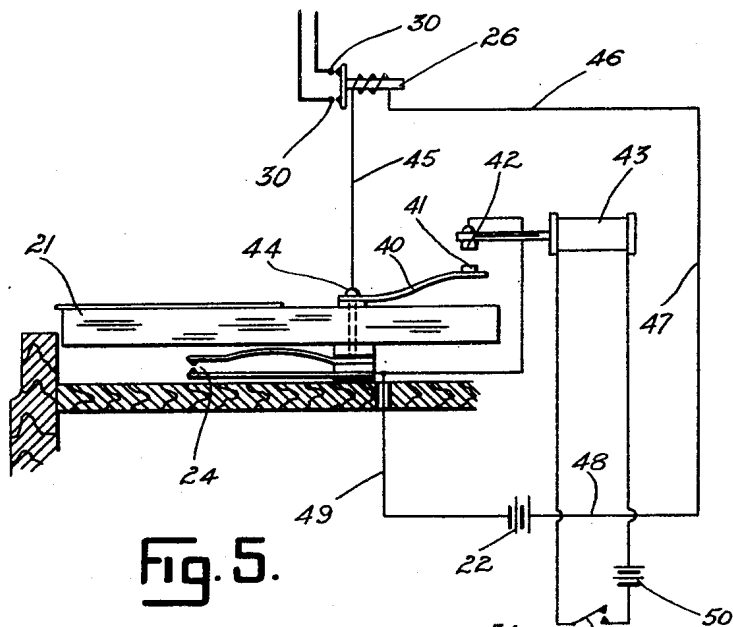

Fig. 5.

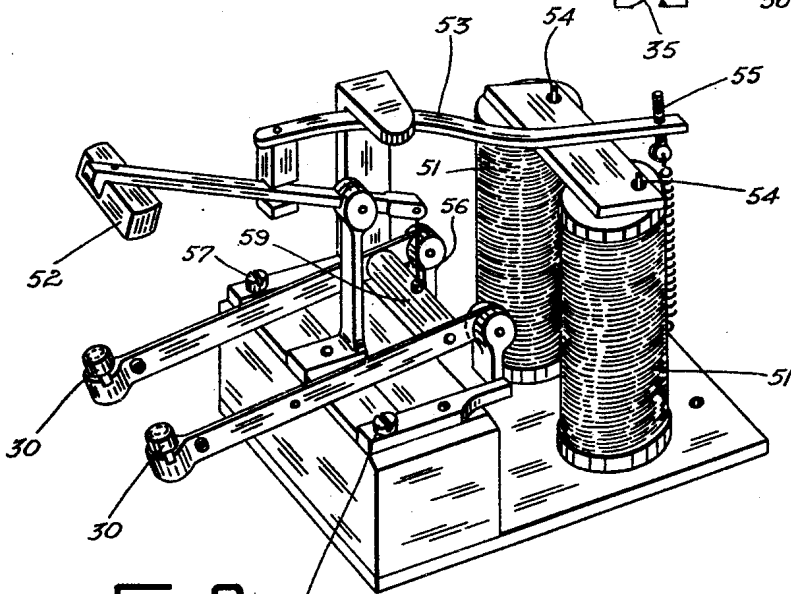

Fig. 6.

Inventor:  
Alexander Burnett Hector.  
By *Samuel L. Norris*,  
Attorney.

# UNITED STATES PATENT OFFICE

ALEXANDER BURNETT HECTOR, OF GREENWICH, NEAR SYDNEY, NEW SOUTH WALES,  
AUSTRALIA

## PRODUCING COLOR MUSIC AND OTHER SPECTACULAR LUMINOUS EFFECTS

Application filed July 7, 1927, Serial No. 204,086, and in Australia July 15, 1926.

This invention has reference to improvements in, and relating to the production of color music or the harmony of color and musical sounds, and other spectacular effects, and apparatus therefor in which the movements of the keys of a piano, piano player, organ, or other keyboard are made to operate a series of switches and/or relays so as to display or project colored lights in such manner as to harmonize with musical sounds.

The main object of the invention is to express more effectively by means of lights the emotions of a musician, through the keyboard of a musical instrument or the like. There may be used in some instances, a silent keyboard, that is, without the agency of sound, to produce luminous displays.

The invention consists briefly of the arrangements and/or projection of colored lights according to a color scale of treble and bass notes and in apparatus whereby the mechanism of piano players, organs, or other keyboard instruments may be conveniently utilized to obtain the desired effects, and in means for the reflection and diffusion of light and the production of shadows.

It is well known that if the space occupied by the normal spectrum be divided, the various colors occupy different proportions of this space. The ratios of each color may be determined and form the basis for a color scale.

Advantage is taken of this to construct what is termed a color scale of treble and bass notes.

In applying the color scale to the keys of a keyboard musical instrument I start at the lowest bass note and proceed upwardly.

The scale or ratio of the spectrum colors may be arranged over the various keys and octaves in several ways.

In applying the lighting effects the use of a spiral, known as the logarithmic spiral, the nebular hypothesis, the aurora borealis, or vortices is resorted to, that is to say, I have ascertained that all sound harmonics are curves or spirals and that the nearer the approximate curve or spiral is to the presentation of light, the closer the simultaneous harmonic effect of sound and light, and in

this manner the form and color of music are rendered visible. In short the analogy of the "spinning electron" is followed.

The invention, in its simplest practical form, comprises a plurality of electric lamps arranged according to the chromatic scale of colors, in segments of a circle or spiral which segments or sectors may extend from the periphery to a center, and the color in each sector is graduated or shaded from the periphery to the center. Preferably, however, one or a plurality of electric lights of graduated size is provided to correspond with one or a series of pendulums of different lengths on which said lights are mounted or carried. By these means the lights take the swinging motion of their respective pendulums imparted from the keyboard until they slow down to a state of rest or are stopped by a pedal or other means controlled from the keyboard. The pendulums may be provided with universal joints whereby a vortex, to and fro, or other rhythmic movement, may be obtained.

The pendulums and the lamps thereon may be arranged in units of seven, the size varying geometrically. Twelve of such units, when fixed in a common circle, will be arranged to form a logarithmic spiral. The lights in a series may be shrouded from the other lights in that series.

The lights or lamps may be mounted on telescopic or lazy tong mechanism to vary the intensity or area of the lighting effect.

The apparatus may be portable and the keys or hammers of a keyboard instrument may be provided with metal contact strips to close an electric circuit on their depression.

However in order that the invention may be more readily understood, reference will now be made to the accompanying drawings, wherein:—

Figure 1 is a diagrammatic view of one form of the invention showing the arrangement of lights in the form of a logarithmic spiral and the musical instruments and relay box associated therewith.

Figure 2 is a diagrammatic view showing part of the circuit arrangement for controlling the lights from a keyboard, the dis-

position of the lights being in the form of a logarithmic spiral shown in elevation.

Figure 3 is a diagrammatic plan view of the logarithmic spiral shown in Figure 2.

5 Figure 4 is a part diagrammatic inverted plan view of the arrangement of lights in groups or clusters in a dome also in the form of logarithmic spirals.

10 Figure 5 is a sectional view of one of the keys of a keyboard instrument, illustrating an alternative circuit arrangement for producing a sustaining effect on the lights.

15 Figure 6 is a perspective view of a suitable form of quick acting relay for closing the lamp circuits.

Referring to Figures 1 to 6, the piano 15 and organ 16 are electrically connected in multiple to relays in the relay box 17. The relays may be of any suitable type but are preferably of the quick acting type shown in Figure 6. Each relay is controlled by a switch operated by one of the keys of the musical instrument and is adapted to complete the circuit for the respective lamps or groups

25 of lamps under its control. The lamps 18, which may have reflectors 19, are arranged in the form of a logarithmic spiral, shown in dotted lines in Figures 2 and 3, and diagrammatically as clusters of lamps in Figure 4. Each turn of the spiral represents one octave and is composed of twelve lamps or groups of lamps. For a seven octave keyboard instrument a seven turn logarithmic spiral in which each turn has twelve lamps or groups of lamps would be provided.

30 In Figure 4 seven clusters of lights 20 are shown, each of which is controlled by the same note in the seven respective octaves of the keyboard instrument. In a similar manner the other eleven notes of each octave would each control a cluster of lights arranged in a similar way to those shown in the drawing.

40 Beneath each note contacts are arranged, (see Figures 2 and 5). These are adapted on the depression of a note to complete a circuit for energizing a relay whereby a lamp, or group or cluster of lamps is lighted.

Referring to Figures 1 to 4, when one of the keys 21 of the piano 15 or organ 16 is struck by a musician or mechanical player, the following circuit is completed: from battery 22, contact bar 23, contact 24, wire 25, relay 26, wires 27, 28 and 29, back to battery 22. When the above circuit is completed, the relay 26 closes contacts 30 and completes the following lamp circuit: from positive main 31, wire 32, lamp or lamps 18, wire 33, to the negative main 34.

50 In order to sustain a particular lamp or lamps after a particular key has been played, additional contacts 39 are provided on the relay 26 in order to effect a locking circuit for the relay, which operates as follows. Upon the closing of a pedal or like operated switch 35, a circuit is completed as follows: from

battery 22, switch 35, wires 36, 37 and 38, contacts 39, relay 26, wires 27, 28, 29, to battery 22. From the above circuit it will be seen that if a particular key is played and the respective relay contacts closed, the lamp will remain lighted provided the sustaining switch 35 is closed, causing the relay to be energized by the sustaining circuit. If the particular key returns to its normal position and opens switch 24, the particular lamp will remain lighted so long as the sustaining switch 35 is closed.

70 In the modified sustaining mechanism shown in Figure 5, each of the keys 21 of the keyboard instrument has a back contact member 40 which is springy and has a soft iron tip or keeper 41. A soft iron bar 42 is supported by and capable of being magnetized by an electromagnet 43 mounted above the keyboard of the instrument and extending longitudinally thereof and which when magnetized is capable of retaining the tip or keeper 41 in contact therewith once a key has been depressed, and during such time as the sustaining switch 35 is closed by a pedal or like operating means to complete an independent circuit for energizing the electromagnet 43. When a keyboard instrument is installed with the modified arrangement shown in Figure 5, the lamp circuit closing relay is energized as follows. When a particular key 21 is depressed current flows from battery 22 by way of wire 49, contact 24, screw 44, wire 45, lamp circuit closing relay 26, wires 46, 47, 48, back to battery 22. The energization of the relay 26 causes the contacts 30 to close the lamp circuit of the particular lamp or group of lamps corresponding to the note struck.

80 If it is desired to sustain the lamp in lighted condition, the sustaining switch 35 is closed to energize the electromagnet 43 by means of current supplied from battery 50.

This has the effect of magnetizing the bar 42 so that when a particular key is struck the back contact member 40 is raised until the tip or keeper 41 engages the magnetized bar 42 against which it is held as long as the switch 35 is closed. Current will now pass from battery 22, wires 49, 51, bar 42, contact member 40, wire 45, relay 26, wires 46, 47, 48, back to battery 22, with the result that relay 26 maintains the lighting current of the particular lamp closed as long as the sustaining switch is closed, even when the note 21 returns to its normal position.

90 Figure 6 illustrates one of the lamp circuit closing relays 26 which are of the quick acting type. Each relay has electromagnetic coils 51 and contacts 30 which are bridged by the keeper 52. The operating arm 53 is secured to the armature of the relay and is loosely pivoted on pins 54, adjustment being effected by the screw 55. In operation, this relay works as follows. When the coils are energized the armature is attracted, causing

the arm 53 to depress the keeper 52, and at the same time the coupling 56 raises the contacts 30 which, on engagement with the keeper, completes the circuit from terminal 57 to terminal 58. The contacts 30 are normally insulated from each other by a distance piece 59.

The lamps 18 with their reflectors 19 may be mounted on a universal joint 83 and be arranged to swing with a pendulum action when released by an electromagnet 84.

I claim:

1. In improvements in the production of color music and other spectacular luminous effects, the combination of a controlling keyboard of a musical instrument, a source of electrical energy, a plurality of circuits controlled by the keys of the keyboard, and a number of colored lights adapted to be controlled by the keys of the keyboard, said lights being arranged in the form of a logarithmic spiral.

2. In improvements in the production of color music and other spectacular luminous effects, the combination of a controlling keyboard of a musical instrument, a source of electrical energy, a plurality of circuits controlled by the keys of the keyboard, and a number of colored lights, representing a color scale corresponding to treble and bass notes, said lights being arranged in the form of a logarithmic spiral and each coil of the spiral representing one octave and comprising at least twelve lamps.

3. In improvements in the production of color music and other spectacular luminous effects, the combination of a controlling keyboard musical instrument, a source of electrical energy, a plurality of circuits controlled by the keys of the keyboard, and a number of colored lights representing a color scale of treble and bass notes, said lights being arranged in the form of a logarithmic spiral and adapted to be electrically controlled from the keyboard, and means common to each circuit for sustaining the energization of the lights at will.

4. In improvements in the production of color music and other spectacular luminous effects, the combination of a controlling keyboard musical instrument, a source of electrical energy, a plurality of circuits controlled by the keys of the keyboard, so that on depressing one of the keys of a keyboard an electrical circuit is completed, a relay in each circuit and contacting a lighting circuit for a colored lamp that forms part of a color scale corresponding to treble and bass notes arranged in the form of a logarithmic spiral, and a switch operable at will to close an independent circuit to the relays in order to sustain the lighting circuit in the closed position after the key is released and returns to its normal position.

5. In improvements in the production of

color music and other spectacular luminous effects in combination, a keyboard musical instrument, a source of electrical energy, a plurality of circuits, a series of electric lamps arranged in the form of a logarithmic spiral, at least one lamp to a key, electrical contacts closed by the keys of the musical instrument to close a circuit including a lamp and the source of electrical energy, lamp circuit closing relays, one to each key, controlled by said contacts, and a manually operated switch adapted to complete a circuit for sustaining said relays in energized condition after the keys of the musical instrument have returned to the normal position.

6. In improvements in the production of color music and other spectacular luminous effects in combination, a keyboard musical instrument, a source of electrical energy, a plurality of circuits including said source, a series of electric lamps arranged in the form of a logarithmic spiral, normally open electrical contacts one to each key adapted to be closed by the keys, lamp circuit closing relays controlled by said contacts, one to each contact and its key, a manually operated switch adapted to complete a circuit for sustaining said relays in energized condition after a key has been depressed, closed its contacts to cause the energization of the relay and been released, and sustaining means comprising a manually operated switch and relay contact adapted to close a circuit for energizing the relay.

7. In improvements in the production of color music and other spectacular luminous effects in combination, a keyboard musical instrument, a source of electrical energy, a plurality of circuits including said source, a series of electric lamps arranged in the form of a logarithmic spiral, electrical contacts, one to each key, adapted to be closed by the keys, lamp circuit closing relays controlled by said contacts, one to each contact and its key, a manually operated switch adapted to complete a circuit for sustaining said relays in energized condition after a key has been depressed, closed its contacts to the keys to cause the energization of a relay and been released, and sustaining means comprising a contact blade on each key, said contact blade having a soft iron keeper adapted to retain the contact on a closed condition when attracted by an electro-magnetic bar under the control of an electro-magnet energized by closing said manually operated switch, said contact blade completing an independent circuit for energizing the lamp circuit relay.

In testimony whereof I have hereunto set my hand.

ALEXANDER BURNETT HECTOR.