

(No Model.)

E. BERLINER.
GRAMOPHONE.

No. 564,586.

Patented July 28, 1896.

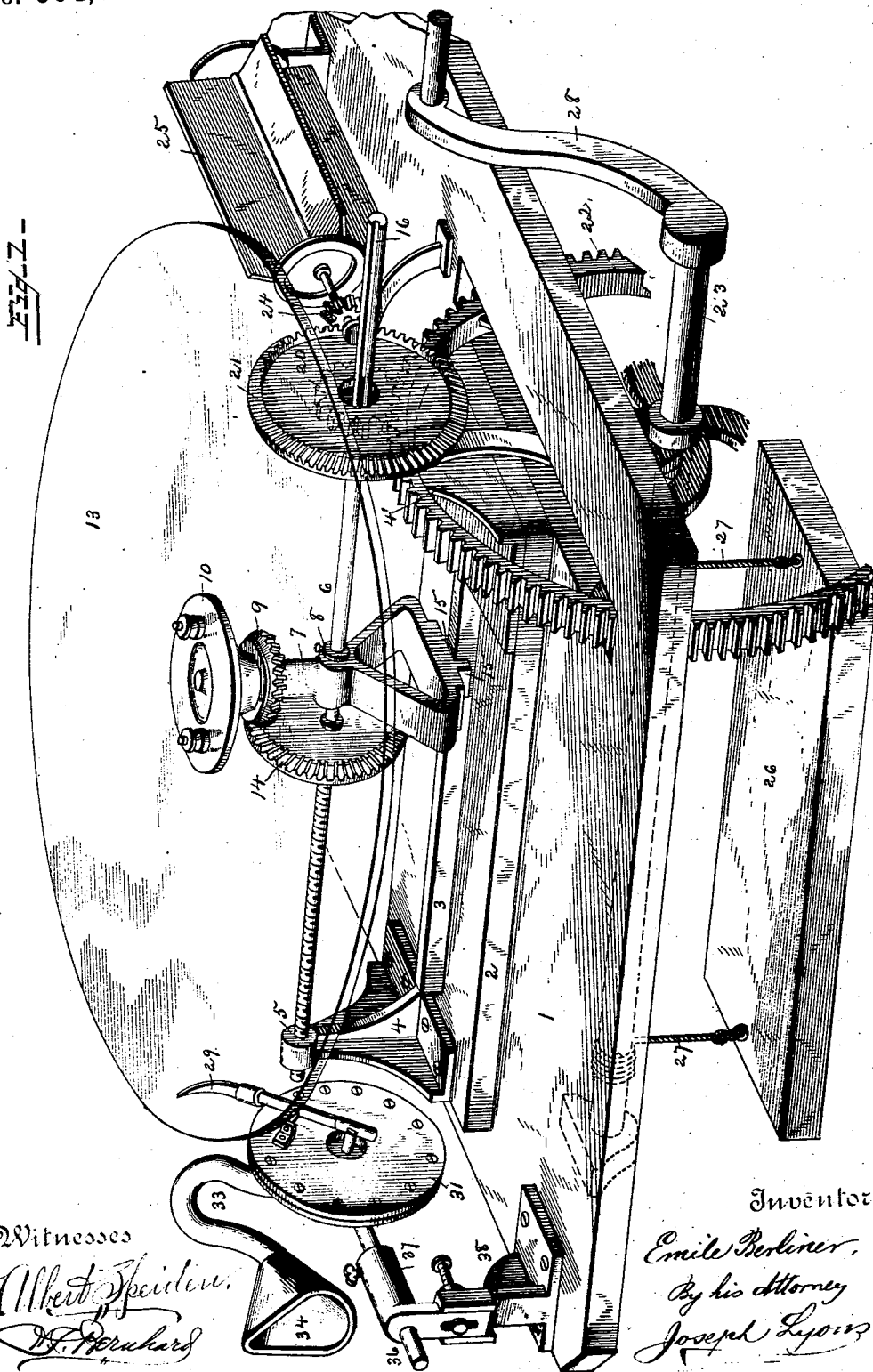

Witnesses
Albert Speiden.
D. Percher.

Inventor
Emile Berliner.
 By his attorney
Joseph Lyons.

(No Model.)

3 Sheets—Sheet 2.

E. BERLINER.
GRAMOPHONE.

No. 564,586.

Patented July 28, 1896.

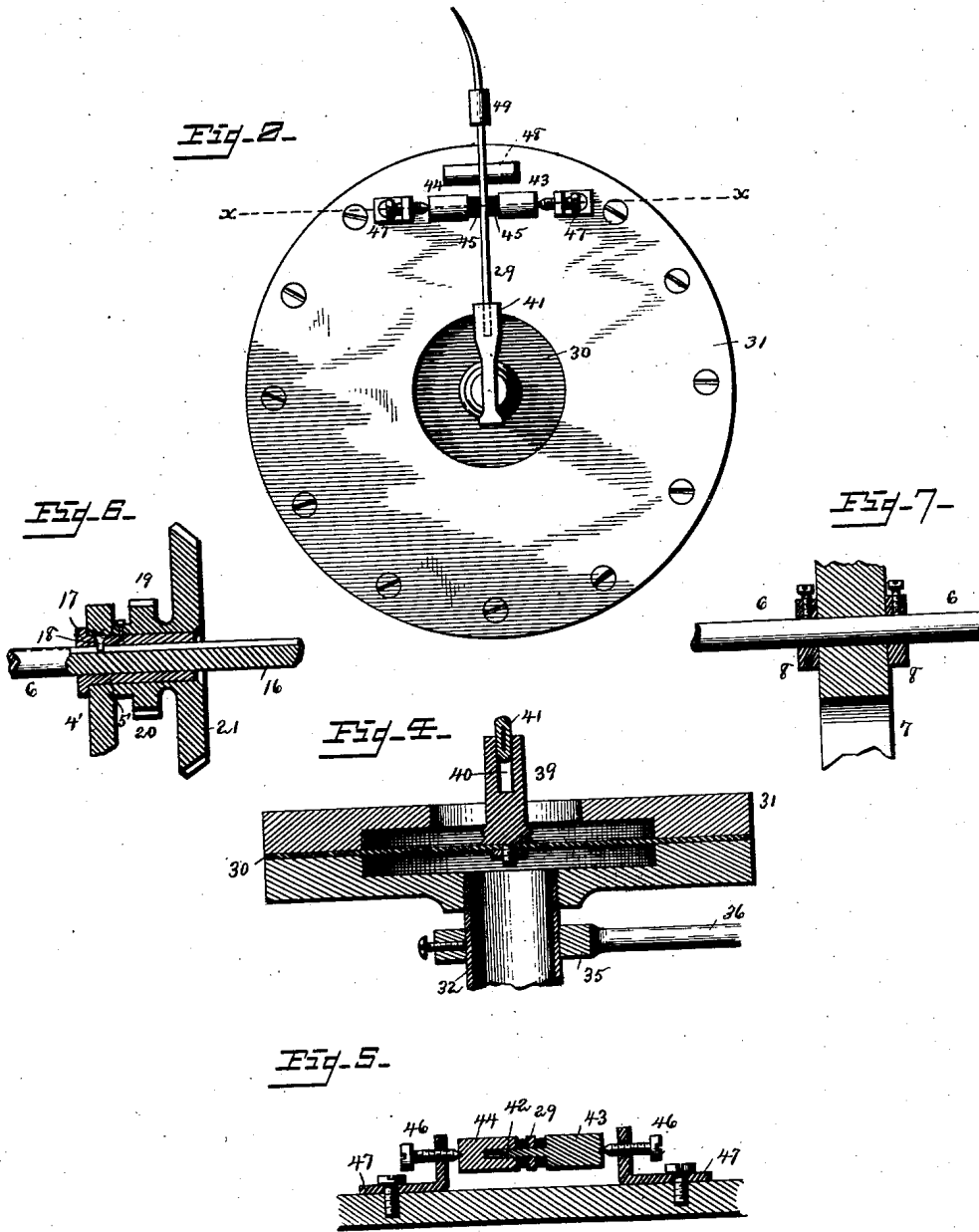

Witnesses

Albert Spiden,
W. F. Beruhard

Inventor

Emile Berliner,

By his Attorney

Joseph Lyons.

(No Model.)

3 Sheets—Sheet 3.

E. BERLINER.
GRAMOPHONE.

No. 564,586.

Patented July 28, 1896.

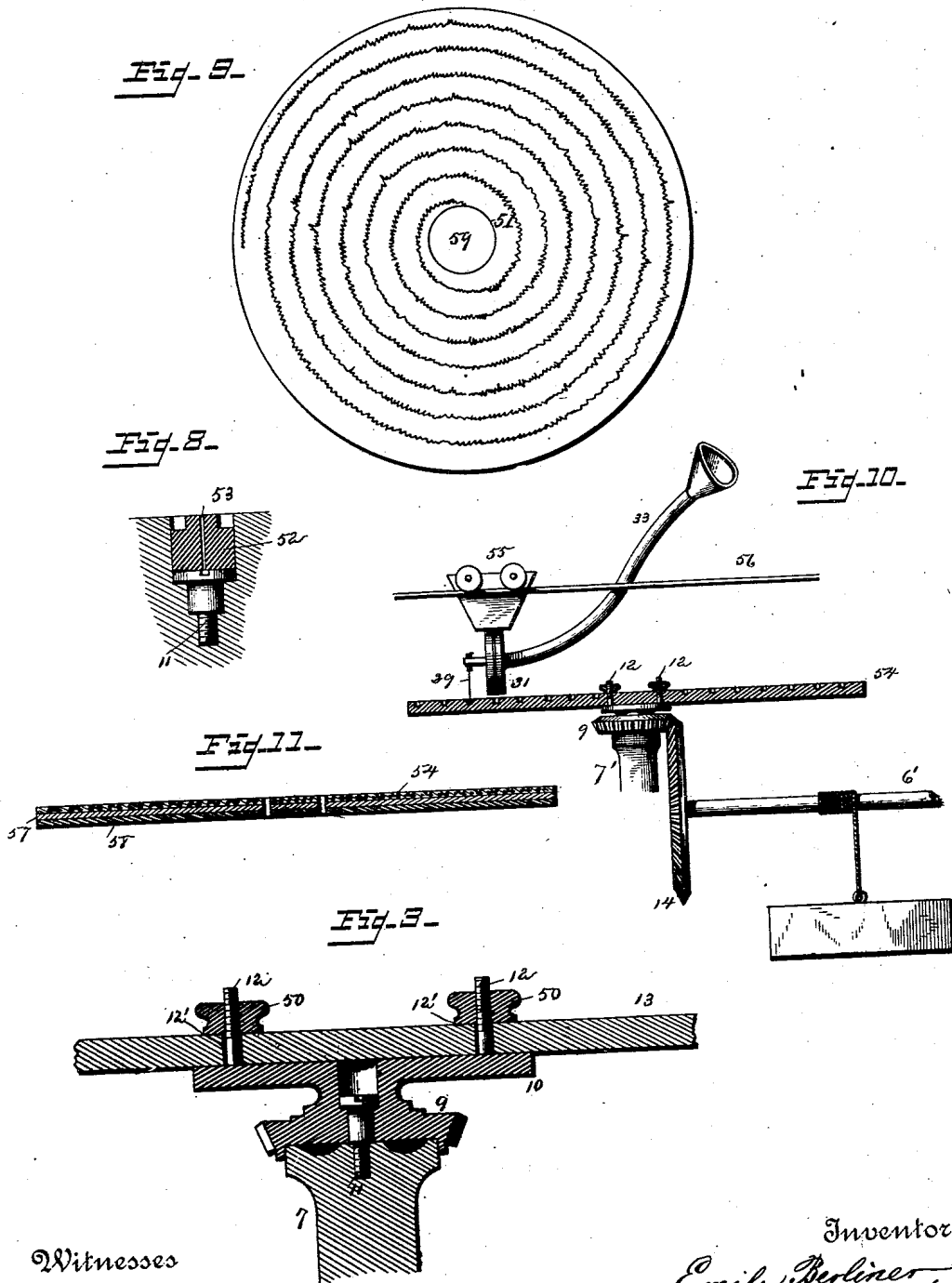

Witnesses

Albert Speiden,
H. P. Percher

Inventor

Emile Berliner,

By his Attorney

Joseph Lyons.

UNITED STATES PATENT OFFICE.

EMILE BERLINER, OF WASHINGTON, DISTRICT OF COLUMBIA, ASSIGNOR,
BY MESNE ASSIGNMENTS, TO THE UNITED STATES GRAMOPHONE COM-
PANY, OF WEST VIRGINIA.

GRAMOPHONE.

SPECIFICATION forming part of Letters Patent No. 564,586, dated July 28, 1896.

Application filed November 7, 1887. Serial No. 254,541. (No model.) Patented in England November 8, 1887, No. 15,232.

To all whom it may concern:

Be it known that I, EMILE BERLINER, a citizen of the United States, residing at Washington, in the District of Columbia, have invented certain new and useful Improvements in Gramophones, of which the following is a specification.

My invention has reference to improvements in methods of and apparatus for recording and reproducing spoken words and other sounds, and it is primarily intended as and constitutes an extension and improvement of my gramophone which I have described in Letters Patent No. 372,786, granted to me on November 8, 1887, and for which I have also received Letters Patent of Great Britain, No. 15,232, dated November 8, 1887. In said patents I have described a method of recording and reproducing sounds, which consists in first causing the sounds to inscribe themselves upon a layer of non-resisting material in a manner substantially like that practiced by the well-known Leon Scott phonautograph, then copying the phonautographic record in solid resisting material, preferably by the photo-engraving process, and then reproducing the sounds from the solid copy of the record. The original record, as well as the copy of the same, is thus obtained as an undulatory line of even depth, as distinguished from a line of varying depth obtained by the ordinary phonograph and by the graphophone.

In my present invention I retain all the fundamental features of my gramophone, but introduce certain novel features both in the process and in the apparatus, which render the attainment of the objects of a sound recorder and reproducer more certain and more perfect.

In the original form of my gramophone I employed a curved (cylindrical) surface upon which the non-resisting medium used for recording was supported. This had the disadvantage that for the purpose of copying the record by the photo-engraving process such surface had to be first straightened and the flat copy obtained from the same had to be bent again to the original cylindrical form of the record-surface. This involved delicate and tedious manipulations, which I avoid in

my present invention by inscribing the record of sounds upon a flat plate, and I further improve the process by arranging that flat plate horizontally, or nearly so, and by inscribing the record upon the under surface of the same, whereby the material removed by the recording-stylus drops away from the plate and leaves the undulatory groove of even depth, clean, and well defined, whereas by the old method the material removed by the stylus accumulated in and about the adjacent grooves.

I have further improved the process by using a transparent plate as a support for the non-resisting medium. This plate is therefore made either of glass or some other like substance, whereby I secure several important advantages. The most important of these advantages is that it enables me to work with parallel transmitted rays of light in the subsequent process of photo-engraving, in which the original record is thus used as a negative, which may be directly applied in contact with the sensitive photographic plate, and another important advantage is the reduction of the friction of the stylus upon the supports to a minimum.

The process is further improved by the employment of a new recording medium. In the original process I used a layer of lampblack pure and simple, and this substance is well adapted for the purpose on account of the slight coherence of the particles; but by reason of the flocculent nature of this substance the lines drawn upon it are more or less ragged, as can be observed under a microscope, and the photo-engraving obtained from such record displays all the defects of the original. In my improved process I employ a layer of a semifluid ink or paint, of such consistency and thickness that it will neither subside nor flow spontaneously. Such ink is practically structureless, and the lines drawn upon it are exceedingly sharp and reveal no ragged edges under a powerful microscope, and the photo-engraving from such record is far superior to a like copy from a record produced under the former process.

My invention also comprises other minor improvements in the process, and it also covers novel features in the apparatus, all of which

will more fully appear from the following detailed description, in which reference is made to the accompanying drawings, in which I have illustrated convenient forms of apparatus which I have used, without, however, limiting myself to the exact details of the same.

Figure 1 is a perspective view of my improved gramophone. Fig. 2 is a plan view of the diaphragm, with its support and accessories. Fig. 3 is a vertical section showing the recording-disk and its connection with the driving-wheel. Fig. 4 is a sectional view of the diaphragm, its support, and accessories. Fig. 5 is a cross-section on line *x x* of Fig. 2. Fig. 6 is a sectional view of a part of the driving-gear. Fig. 7 is a section showing the connection of the driven shaft with the support of the recording-disk. Fig. 8 is a sectional view of a centering device. Fig. 9 is a plan view, upon a reduced scale, of a disk with a record of sounds recorded upon the same in accordance with my invention. Fig. 10 is a sectional elevation of a modified form of my reproducing apparatus, and Fig. 11 is a sectional view of a dampened reproducing-disk.

Referring now to the drawings, in which the details are marked by numerals, there is a platform 1, suitably supported, and upon this platform are mounted the operative parts of the apparatus. A metallic plate 2, provided with a longitudinal rib 3, is secured upon the platform, and standards 4 4', mounted upon plate 2, are provided with a nut-bearing 5 and a smooth bearing 5', (see Fig. 6,) respectively, for shaft 6, which extends through these bearings, as shown. One-half, more or less, of this shaft is screw-threaded, as shown, and enters the nut-bearing 5, and at a point near the middle said shaft passes loosely through a movable support 7, the position of which upon the shaft is determined by two collars 8 8, as indicated in Fig. 7.

The support 7 serves as a bearing for a bevel-gear 9, which is centrally perforated and widens out into a circular flange 10. Upon its under side the bevel-gear 9 is recessed, and said recess fits loosely over the upper end of support 7. A screw 11, passing loosely through the central perforation of bevel-gear 9, screws into the head of support 7, so that the bevel-gear can rotate about its axis, which coincides with the axis of screw 11. Two screw-pins 12 12, which may be either fixed or removable, project at diametrically opposite points from flange 10, and are designed to pass through two similarly-located holes in a glass plate 13, as will be more fully described hereinafter.

A bevel-gear 14, fixed upon shaft 6, engages bevel-gear 9, but provision is made for releasing gear 14 from the shaft, if desired, for a purpose which will be explained farther on. As stated above, the screw-threaded portion of shaft 6 passes through nut-bearing 5, and it will now be clear that if shaft 6 is rotated bevel-gear 9, with its flange 10, will likewise rotate, and will at the same time ad-

vance in a straight line, since shaft 6, screwing into or out of its nut-bearing 5, will carry bevel-gear 14 and support 7 with it. From the bottom of support 7 two lugs 15 15, one on each side of rib 3 of plate 2, serve to guide the support with the parts attached thereto in the line of said rib, which is, of course, parallel to shaft 6.

A part of the smooth portion of shaft 6 has a longitudinal groove 16 extending to the right-hand end of the shaft, as seen in Figs. 1 and 6, and a sleeve 17 loosely fitting this portion of the shaft has a pin 18, the end of which engages groove 16, as shown in Fig. 6, so that the shaft is free to slide longitudinally through sleeve 17 and will rotate with the same if the latter is rotated.

Sleeve 17 is fitted into bearing 5' of stand-ard 4', so as to rotate within the same, and upon that part of the sleeve which projects beyond the bearing is keyed the compound gear 19. The latter is composed of a pinion 20 and a bevel-gear 21, and a rather large bevel-wheel 22, mounted upon a shaft 23 below platform 1, meshes with pinion 20.

A small bevel-gear 24 meshes with gear-wheel 21, and to the shaft of gear 24 are secured fans 25, which are thus driven at a high speed and serve as a regulator, as will be readily understood by those skilled in the art.

A weight 26 is suspended by cords or chains 27 from shaft 23, and if said shaft is turned by a crank 28, or otherwise, in one direction the cords or chains are wound upon the same, as indicated in Fig. 1, and the weight 26 is raised up toward the platform. If, on the other hand, the weight is allowed to descend, it will rotate shaft 23, this in turn will rotate gear-wheel 22, which, meshing with pinion 20, will rotate the latter and the connected shaft 6, and in the manner hereinbefore described support 7 will receive a rectilinear motion, while flange 10, upon bevel-gear 9, will both rotate and move in a straight line. For every complete revolution of bevel-gear 14 support 7 and bevel-gear 9, with its connected flange 10, will be moved in the line of a diameter a distance equal to the pitch of the screw-threads upon shaft 6, and it will now be understood that if a plate 13 is fixed to flange 10 and a fixed pencil or stylus be lightly pressed upon the plane surface of said plate a spiral line will be drawn upon the plate.

The recording-stylus 29 is mounted upon a diaphragm 30, and the diaphragm itself, which may be of any suitable sonorous material, is mounted in a case 31, and a rigid tube 32, projecting from one side of the case, communicates with a flexible tube 33 and a mouth or ear piece 34. The tube is clamped and may be adjusted in the direction of its length in a ring 35, formed at the end of a rod 36, which is adjustable in a support 37, and the latter is again adjustable vertically in a standard 38 mounted upon platform 1. A

metal post 39 is fixed to the center of the diaphragm, as shown, and its free end has an axial slot 40, into which a soft-rubber tube 41 is forced and flattened. The free end of the soft-rubber tube receives the stylus 22, which may be of metal or any other hard and fairly elastic material.

Preferably the stylus is made of a flat strip of phosphor-bronze extending radially over the face of casing 31 and some distance beyond the edge of the same. At its free end the stylus is reduced to a point and is curved upwardly, and by turning the diaphragm-case about the axis of tube 32, or by turning rod 36 in its bearing 37, or by adjusting the latter upon bracket 38 the point of the stylus may be brought into light contact with the lower face of disk 13 at a point in the diameter of said disk which is parallel with shaft 6. Near the middle of its length a hole is produced through the stylus, and a pin 42, formed at one end of a metal block 43, passes through said hole and into the central bore in a similar block 44. Between each block and the adjacent face of the stylus a soft-rubber washer 45 is inserted, and the two blocks are forced together and are made to clamp the stylus between the rubber washers by means of the pointed screws 46, working in the supports 47. The screws 46 46 thus constitute the pivotal supports of the stylus, which is a true two-armed lever. A piece of soft-rubber tubing 48 is inserted between the outer arm of this lever and the casing 31, and another piece of soft-rubber tubing 49 is slipped over the stylus between the elastic support 48 and the outer end. Thus it will be seen that the stylus is elastically supported and amply dampened, and that if the diaphragm vibrates under the impact of sound-waves the free end of the stylus will move to the right and to the left of its position of rest and parallel to the face of disk 13.

The disk 13 is preferably made of glass. It is of suitable diameter and thickness, and has two holes 12', 12', corresponding to the pins 12 12 projecting from flange 10, and is placed in position upon said flange with the pins entering the holes. The nuts 50 50 are then screwed down, whereby the glass disk is securely clamped.

The method of recording and reproducing recorded sounds by means of this apparatus will now be easily understood.

As has been stated above, the non-resisting material upon which the sound-record or phonautogram is produced is a semifluid, and I can use for this purpose any ink, as, for instance, printers' ink, of the required consistency. An even layer of this ink may be spread over the under surface of the glass disk in any suitable manner, as, for instance, by means of a brush or roller while the disk is slowly turned; but I prefer to produce the ink directly upon the disk itself, and I proceed in the following manner: The under surface of the glass disk is first carefully pol-

ished and dried, and is then covered with a thin film of oil by means of a camel's-hair brush. This is done while the disk is rotated with moderate speed. Any oil or fat may be used, but I have found linseed-oil specially adapted for the purpose. A smoky flame is then held under the glass plate while the latter is slowly rotated, whereby the lampblack ascending from the flame is intercepted by the plate and becomes deposited upon the same in a very fine layer, which, however, is instantly absorbed by and mixes intimately with the thin layer of oil, thus forming a black amorphous ink, covering the under surface of the glass disk in an even exceedingly thin layer. It is essential that the lampblack be deposited upon the oiled disk by the described process of sublimation; that is to say, the carbon particles must reach the disk and mix with the oil at the moment when their transition from the gaseous into the solid state takes place. If it were attempted to apply lampblack already formed by dusting upon the oiled disk, no intimate mixture resulting in an even layer of amorphous ink would be obtained. The coating of ink thus directly formed upon the disk has just the consistency and the thickness required. It will not flow spontaneously, and while it adheres well to the glass plate, it requires only a minimum force to remove it from the same, and the point of the stylus in its passage through the substance of the ink experiences no perceptible resistance. The disk is now ready to receive the phonautogram, and it is moved to the position shown in Fig. 1, with the point of the stylus near the outer edge. The point of the stylus is then adjusted into light contact with the disk, so that the coat of ink is barely penetrated by the same, and the weight 26 is allowed to descend and to rotate shaft 6 in the manner hereinbefore described. If now the stylus remained immovable, it would describe upon the under surface of the disk a smooth spiral the convolutions of which continuously decrease toward the center of the disk. The pitch of the spiral is determined by the pitch of the screw upon shaft 6 and by the relative angular velocities of said shaft and of bevel-gear 9, and may in practice be made as small as one-fiftieth of an inch. If now during the progress of the disk sound-waves are directed against the diaphragm through the mouth-piece 34 and tubes 33 and 32, the stylus will vibrate to the right and left of the spiral line, inscribing upon the disk an undulatory line of even depth, which line will truly and accurately represent the sounds uttered against the diaphragm. The stylus removes a very sharp line of ink from the disk, leaving the latter quite transparent at this line, while it is quite opaque and will not transmit light at the places not touched by the stylus. The ink removed by the stylus drops away from the disk, as stated above, and does not accumulate in and about the grooves.

An approximate idea of the phonautogram thus produced can be obtained by inspection of Fig. 9, which represents an undulatory spiral line upon a disk, with the pitch of the spiral and the undulations of the record greatly exaggerated. In the drawings, the undulatory line appears black upon a white ground, while in fact the line is transparent upon a black ground.

The phonautogram may extend to within a short distance from the edge of flange 10, and in practice the cords or chains 27 27 are made just long enough to drive the disk up to that limit, or the apparatus is mounted at the proper height above the ground so that the weight will be arrested before the limit of progress of the disk is reached. Bevel-gear 14 is then disengaged from bevel-gear 9 by unclamping the same from shaft 6 and sliding it upon the same a short distance to the left hand, (in the view shown in Fig. 1.) and the disk is then given a single rotation by hand, whereby the stylus describes a true circle 51 upon the disk. This circle, which I call the "centering-circle," is afterward utilized, as will presently appear. The glass disk, with the sound-record and centering-circle upon the same, is now removed, and the record may be fixed by applying a thin coat of varnish. It may then be handled with impunity. From this record I produce a copy in copper or any other metal by the process of photo-engraving, and in this process I use the original record as a negative, which enables me to work by transmitted light and with parallel rays, the negative being applied directly in contact with the sensitive photographic plate. The copy thus produced will have the exact size of the original, as is well understood by those skilled in the art. In the photo-engraved copy the sound-record appears as an undulatory line of even depth upon a solid metal disk, and the centering-circle 51 is reproduced in the same manner.

For reproducing the original sounds, the center of the centering-circle is determined by well-known simple geometrical constructions, and a small hole is drilled through that center, which hole corresponds to the mathematical axis about which the glass disk had been rotated, and also marks the axis about which the metal disk must be rotated by the apparatus shown in order that the pointed stylus applied to the starting-point of the record may follow the same from beginning to end. Two holes corresponding to the holes 12' 12' in the glass-disk are also made in the metal disk, but these holes are preferably made large enough to permit the disk to be adjusted in either direction when placed upon flange 10. Before this is done a well-fitting cylindrical block 52 is placed into that part of the cylindrical hole through the common center of flange 10 and bevel-gear 9 which is occupied by the head of screw 11, as shown in Fig. 8. This block, which I call

the "centering-block," has a fine axial hole 53, which corresponds exactly to the mathematical axis of rotation of bevel-gear 9. If now the photo-engraved copy of the record is placed upon flange 10, with pins 12 12 passing through corresponding holes in the metal plate, a fine pin, say a sewing-needle, is passed through the centering-holes in the disk and in block 52, and the clamp-nuts 50 are tightly screwed down. By this simple process the metallic copy of the original record is safely and quickly centered in position. The stylus is then adjusted with its point in engagement with the outer end of the record-groove, and the weight 26 is allowed to descend. It will now be clear that the stylus will be forced positively to follow the undulations of the record, and that the diaphragm vibrating under the stylus will emit the same sounds which produced the original record, which sounds can be distinctly heard at the ear-piece 34.

Both the process and the apparatus thus far described may be modified in various ways without departing from the main features of my invention. So, for instance, I can dispense with the centering device and can rotate the record upon a stationary axis, if the diaphragm with its attached stylus is mounted in a manner to make it follow the spiral record. An arrangement of this character is shown in Fig. 10. The reproducing-disk 54 is in this case mounted as hereinbefore described, but without regard to the centering device. The support 7' may be fixed in position so that the bevel-gear 9, mounted upon the same in the manner described with reference to Fig. 3, will turn without progressive motion. Bevel-gear 9, and with it the reproducing-disk 54, are rotated by a bevel-gear 14' upon a shaft 6', to which power is applied by a weight, as shown, or in any other suitable manner. The diaphragm-casing 31 is secured to a small truck 55 upon rails 56 arranged vertically above and parallel with a diameter of the reproducing-disk, and at such height above the same that the stylus 29 will be in engagement with the undulatory grooves of even depth which represent the record of sounds.

The listener applies his ear to the ear-piece, and when the shaft 6' is rotated the stylus and diaphragm will be forced to vibrate, as in the apparatus shown in Fig. 1, but will at the same time move with the truck 55 across the face of disk 54. A tolerably good reproduction may also be obtained by simply holding one end of a reed between the teeth and the other pointed end of the same in engagement with the record-grooves while the disk is rotated.

The frictional contact of the reproducing-stylus with the surface of the ordinary metallic record gives rise to disturbing sounds, and with a view of avoiding the same I mount the reproducing-disk 54 (see Fig. 11) upon a rigid plate 58, and with a sheet 57, of

felt, soft rubber, blotting-paper, or other non-sonorous substance intervening. This dampens the extraneous vibrations of the reproducing-disk and renders the sounds emitted by the diaphragm very clear.

Additional clearness is obtained by nickel-plating the metallic record, which is ordinarily made of copper, since I have found that the sound due to the frictional contact of the stylus with a polished surface of nickel is very faint.

In place of the metallic copy of the original record I can use a copy made of sealing-wax, which is made from a metallic or other copy having the record in raised lines. The metallic copy is for this purpose first oiled and the molten sealing-wax is then poured over it and is then backed by plaster-of-paris or other rigid material. The cast is then easily removed from the metallic matrix and may be used for the reproduction of the recorded sounds, which will be quite clear and remarkably free of the disturbing sounds due to the friction of the stylus, especially when the surface is first gently rubbed with plum-bago.

The metallic copy of the original record is in effect an engraved copper plate, and it may be used as such for printing upon paper, which then yields a copy in raised lines, as is well understood, and from this paper copy the sealing-wax copy or a copy of any other similar material may be made.

I desire to emphasize the fact that my recording and reproducing stylus is a flat elastic strip, which will yield in one direction, but not in the other. For this reason the recording and reproducing surface need not be absolutely plane, and the stylus will still retain contact with the same, while it will be positively moved to follow the undulations of the record in reproducing. The point of the stylus may be made of iridium.

Having now fully described my invention, what I claim, and desire to secure by Letters Patent, is—

1. The method of producing a phonautogram, which consists in removing an undulatory line of even depth of a deposit of ink from a traveling plate, by and in accordance with sound-vibrations; substantially as described.

2. The method of producing a phonautogram, which consists in removing an undulatory line of even depth of a deposit of amorphous ink from a traveling support, by and in accordance with sound-vibrations; substantially as described.

3. The method of producing a transparent phonautogram, which consists in removing an undulatory line of even depth of a deposit of ink from a traveling plate of glass, by and in accordance with sound-vibrations; substantially as described.

4. The method of producing a transparent phonautogram, which consists in removing

an undulatory line of even depth from a deposit of amorphous and opaque material from a traveling support of glass, by and in accordance with sound-vibrations; substantially as described.

5. The method of producing a transparent phonautogram, which consists in removing an undulatory line of even depth extending along a volute, of a deposit of amorphous and opaque material from a rotating disk of glass, by and in accordance with sound-vibrations; substantially as described.

6. The method of producing a layer of semi-fluid ink upon a phonautographic support, which consists in first applying a coat of oil, or other fat, upon the support, and then sublimating upon the oiled surface a thin layer of lampblack; substantially as described.

7. The method of producing a phonautogram, which consists in removing an undulatory line of non-resisting material from the under surface of a traveling plate, by and in accordance with sound-vibrations; substantially as described.

8. In a gramophone, the combination of a sound-receiving sonorous body; with a pivoted stylus controlled by and controlling the same, and a support adapted to carry a phonautogramic recording-surface, or a copy of such record in solid resisting material, traveling in the plane of vibration of the point of the stylus; substantially as described.

9. In a gramophone, the combination of a sonorous diaphragm and a pivoted stylus; with an elastic connection between the diaphragm and stylus, and an elastic reactionary dampening-support for the free arm of the stylus; substantially as described.

10. In a gramophone, the combination of a pivoted stylus, with an elastic connection between the diaphragm and the stylus; substantially as described.

11. In a gramophone, the combination of a vibratory diaphragm and a stylus controlled thereby and controlling the same; with a rubber tube clamped to the diaphragm and connecting the stylus with the latter, and a pivoted support for the stylus between its free end and its connection with the diaphragm; substantially as described.

12. In a gramophone, the combination of a vibratory diaphragm and a stylus elastically connected therewith; with a pivoted support for the stylus located between the free end of the same and its connection with the diaphragm; dampening-washers between the stylus and its pivotal support, and a reactionary dampening-support for the free arm of the stylus; substantially as described.

13. In a gramophone, the combination of a horizontal traveling support for the recording-surface; with a vibratory diaphragm, and a recording-stylus bearing upon the under surface of the support; substantially as described.

14. In a gramophone, the combination of a

metallic record of spoken words or other sounds; with a backing of non-resonant material; substantially as described.

5 15. In a gramophone, the combination of a sound-receiving diaphragm, mounted in a suitable casing; with a tubular sound-conveying stem projecting from the casing, and an adjustable support for the tubular stem; the connection between the casing and tubular stem being such as to permit of the rotation of the casing relative to the stem for adjustment, substantially as described and for the purpose set forth.

10 16. A device for centering a spirally-extending record, of sounds upon a reproducing

apparatus, consisting of a rotatable record-support having a central recess, a block fitting the said recess and having a perforation coincident with the mathematical center of rotation of the record-support, and means for holding the record upon the support, substantially as described. 20

In testimony whereof I have signed my name to this specification in the presence of two subscribing witnesses.

EMILE BERLINER.

Witnesses:

JACOB G. COHEN,
CHAS. W. HANDY.