

# Herman Fritz's Electro Thermo Battery

No. 74,905.

Patented Feb. 25, 1868.

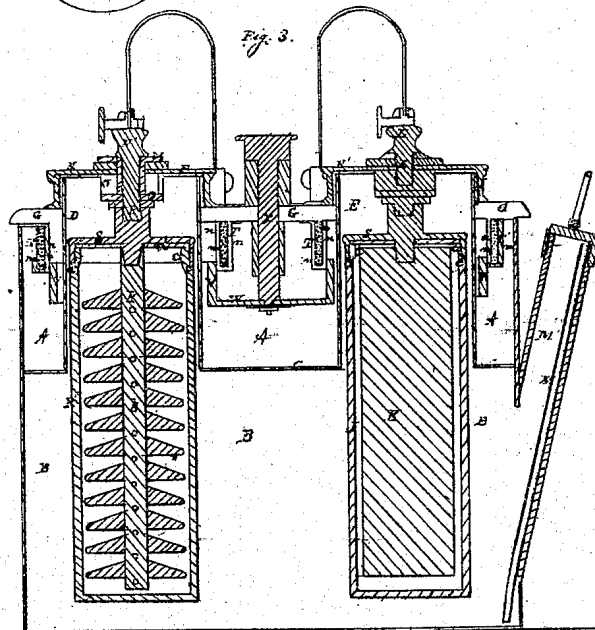
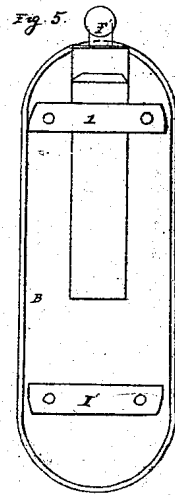
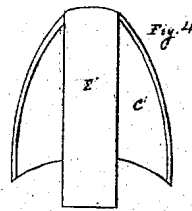
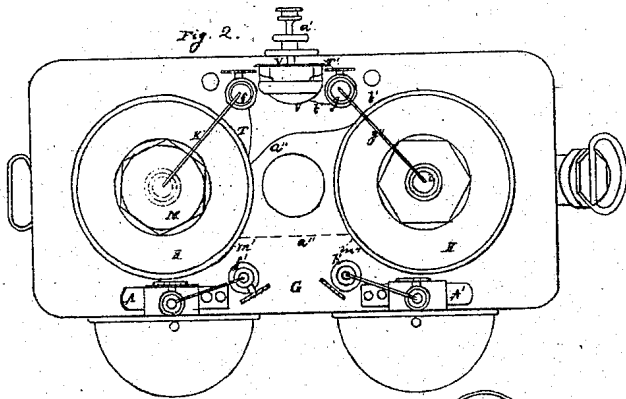
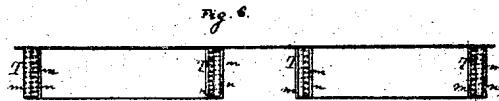
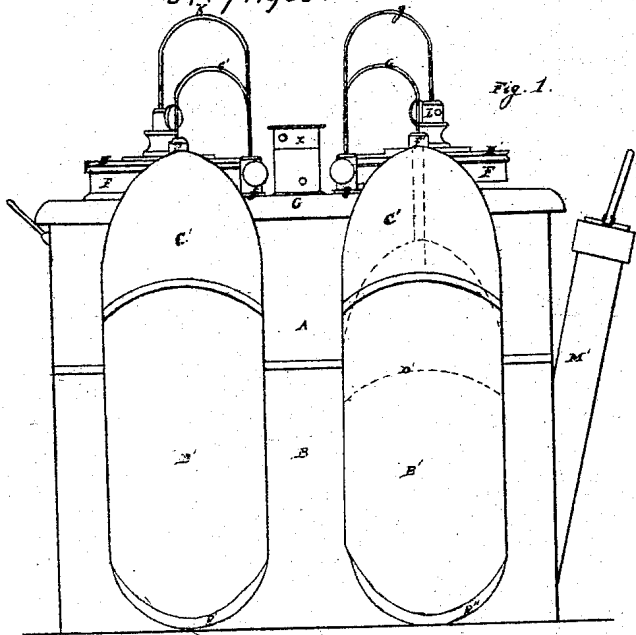

Witnesses.

W. H. Burroughs  
Frank S. Alden.

Inventor, Herman Fritz.

# Herman Fritz's Electro Thermo Battery.

N<sup>o</sup> 74.905.

Patented Feb. 25. 1868.

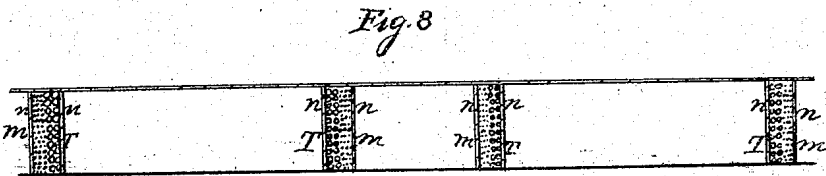
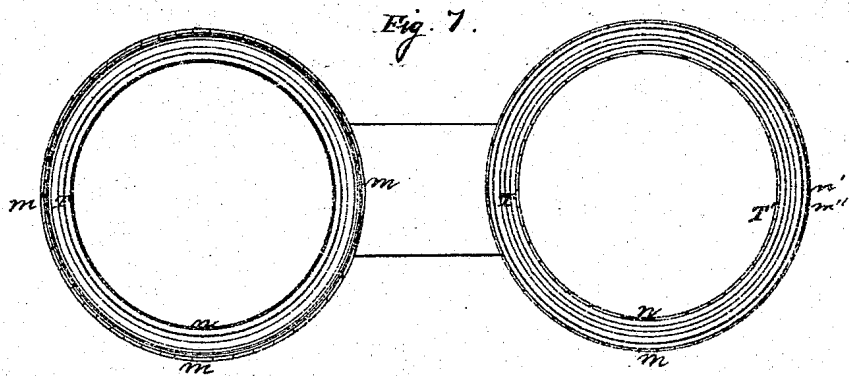

Witnesses.

J. H. Burridge.  
J. Holmes.

Herman Fritz.  
Inventor.

# United States Patent Office.

HERMAN FRITZ, OF CLEVELAND, OHIO.

Letters Patent No. 74,905, dated February 25, 1868.

## IMPROVEMENT IN ELECTRO-MEDICAL BATTERIES.

The Schedule referred to in these Letters Patent and making part of the same.

### TO ALL WHOM IT MAY CONCERN:

Be it known that I, HERMAN FRITZ, of Cleveland, in the county of Cuyahoga, and State of Ohio, have invented certain new and useful Improvements in Electro-Thermal Batteries; and I do hereby declare that the following is a full and complete description of the same, reference being had to the accompanying drawings, making a part of this specification, in which—

Figure 1 is a side view of the battery.

Figure 2 is a view of the top.

Figure 3 is a vertical section.

Figures 4, 5, and 6, 7, 8, are detached sections.

Like letters of reference refer to like parts in the several views.

The case of this battery is constructed of copper and in two sections, an upper and lower one, A B, fig. 3, the two being divided by a diaphragm or partition-plate, C. Proceeding from the lower section, and through the upper one, are a pair of cylinders, D E, the upper ends of which are closed with tightly-fitting caps F, whereas the lower ends open into section B, thereby entirely separating the upper and lower sections from each other. The lower sections, together with the cylinders, are for the purpose of holding the solution and necessary apparatus for producing electrical action. To the upper section is fitted a movable cover or stand, G, which, on being placed in position upon the case, is firmly secured thereto by the ends of the cylinders, which are made to protrude through the cover, and fitted with screw-caps H, which, having a wide edge to the rim, on being screwed down upon the cover, hold it firmly in place. The joint is still further secured by the introduction of gaskets a, the cap thereby making the joint positively tight. These cylinders are negative and positive in their electrical relation, H' being the positive, and E the negative. Projecting downward from the centre of the cap H' is a screw, I, fig. 3, which is solid with the cap. To this cap is attached a porous cup, J, containing a carbon core, K, and solution in which it is immersed. At the top of the cap is a screw-cap, L, for the purpose of attaching a conducting-wire. The opening in the cap of the negative cylinder is provided with a non-conducting lining and washer, M, through which the stem of the screw-cup N' passes, and is thereby insulated from the cap. O is an insulating-washer, forming a part of the lining, and by which the screw P is insulated from the boss O' and the cap or cover of the cylinder. To this screw P may be attached directly the zinc, R; or if so desired for a different battery, a porous cup, R', containing the zinc and solution, may be attached, as shown in the drawing.

The zinc referred to consists of a series of disks, strung upon a rod, and withheld from contact with each other by pins b, projected through the rod and loops arranged on the lower side of the disks. The upper sides of the disks are made convex, so that when they are taken out of the solution the fluid may drop off quickly. By this arrangement of disks, a larger amount of zinc-surface is obtained than by any other arrangement in ordinary use.

The porous cup referred to is a cylindrical clay vessel, the top of which has an outward-projecting flange or shoulder, c'. Above this is a metallic flange, which turns up, and is soldered to a screw-rim, c, fig. 3. This rim rests upon the earthen flange or shoulder of the cup. The cap or cover S is screwed on the rim, and which being provided with a gasket, d, the joint thereby is made securely tight. By this means the porous cup containing the carbon core and solution is brought in direct contact with the whole copper face of the battery-case, there being no insulation of the carbon and cup, as is the case with the zinc and cup; hence the case, on being supplied with the proper solution, and the zinc immersed in the same, and also being insulated in its connection with the case, forms the negative, and the carbon, in its connection with the case, forms the positive pole of the electric action.

The movable stand or cover G of the battery, and to which is attached the electrical apparatus, is designed to be held in the upper section A of the battery-case, and used in connection with the battery, or, if so desired, it can be taken out and connected with the same, or it can be used with any other battery of analogous nature.

The electrical apparatus alluded to is constructed as follows: Below and around the openings in the cover of the case, through which the cylinders E D project, is a pair of helices, T T', figs. 7 and 8; also a primary

coil,  $m' m''$ , of coarse wire, which may either be coiled within or around the induction-coil  $T T'$ , enclosing or surrounding each cylinder. These helices are enclosed in and secured to the cover of the case by a casing constructed of tin,  $m$ , on the outside circumference, and on the inner circumference, by a ring,  $N$ , of platina, joined to the tin, and to the cover of the case. This casing may be constructed of but one kind of metal, or of any other suitable material, and the special purpose of which is to protect the coils from contact with the moisture that may arise from the solution used in the battery.

The two helices are combined into one in the following manner: The inner end of the first prime coil  $T'$ , figs. 7 and 8, (also indicated by the dotted lines  $b'$  in fig. 2,) is connected to the adjusting-screw  $a'$  of the armature  $U'$ , fig. 2, and the outer end to the inner end of the second prime coil  $T$ ; also the outer end of the second prime coil  $T$  is attached to the connecting-post  $f$ , which connects with the zinc or negative pole of the battery. One end of the wire,  $b'$ , coiled around the magnet  $U$ , is fastened to the same, *i. e.*, to the core of the magnet, and the other to the hitching-post  $g$ , which connects with the copper or positive pole of the battery by means of the wire  $y''$ . The inner end of the induction-coil  $m''$ , surrounded by the prime coil above described, and enclosed in the case, as shown in fig. 6, is fastened to a hitching-post,  $h$ , forming the positive pole. The outer end of induction-coil  $m''$  connects with the inner end of induction-coil  $m'$ , as indicated by the dotted lines  $a'''$ , fig. 2. The outer end forms the negative, and is attached to the hitching-post  $f'$ .

Within the platina-cased helices above, is fitted a ring-magnet,  $V$ , and which also fits closely around the cylinders. These two magnets are connected to each other by a bridge,  $W$ , and by which they are moved together upward and downward within the helices by an adjusting-screw,  $x$ , projected above the cover of the battery. By this means are regulated the quantity and intensity of the interrupted electro-current.

Should it be required to use this apparatus without an interrupted current, the cover  $G$  with all its fixtures is removed, and a plain wooden one substituted. This cover, as well as the one with the electro-attachments, is provided with springs  $A'$ , fig. 2, by which the foot-plates  $B'$  are attached to the battery-case. These plates are constructed of two sheets of copper, with a zinc sheet interposed between them. The purpose of the zinc sheet is to add to the thickness and strength of the plates. The edges of one of the copper sheets are turned over upon the other, thereby holding them all closely together. These foot-plates are provided with adjustable toe-caps  $C'$ , so that the foot-plates can be adjusted to different-sized feet by moving the caps upward or downward, as indicated by the dotted lines  $D'$ , fig. 1. The toe-cap is attached to the plate by a slide,  $E'$ , fig. 4, made to fit into a corresponding groove in the plate, indicated by the dotted lines  $j$ , fig. 1, whereby it is adjusted to the size of the patient's feet, and which are supported by the heel-pieces  $R'$  with ease and comfort. On the inner side of the upper end of the foot-plate is attached a hitching-post,  $E'$ , for securing conducting-wires  $G'$  across the back of the plates, and insulating-bars  $I'$ , fig. 5, whereby the foot-plates are insulated from the battery-case. Those on the negative plate are to prevent contact with the surface of the battery, whereas the insulators on the positive foot-plate are designed to cause the heat to feel uniform in both plates when a heated solution is used. The upper insulators being made to fit closely under the projecting edge of the cover, serve to hold the foot-plates from being displaced by the patient.

The practical operation of this apparatus is as follows, *viz*:

When it is desired to apply the prime current to the foot-plates, a wire,  $S'$ , is attached from the insulated cover to the hitching-post of the foot-plate, forming the negative pole. The other cover is connected to the other foot-plate in the same manner, forming the positive pole.

If an interrupted current is desired with the foot-plates, the screw-post in insulating-cover  $H$  is connected to the hitching-post  $f$  connecting with the outer end of the prime coil. The screw-post  $L$  of the positive cover connects with the hitching-post  $g$  connected to the coil of the magnet  $U$ . The foot-plates are connected to the hitching-post connecting with the induction-coils  $m'$ . If no electric current is desired through the foot-plates, the wires are simply removed therefrom, and longer ones inserted when electrodes are required for different parts of the body.

The solution is poured into the case through the side tube  $M'$ , fig. 1, and in which tube is a small pipe,  $N'$ , for the escape of the air on filling the case. The tube also serves as a handle, by which the apparatus is carried.

What I claim as my improvement, and desire to secure by Letters Patent, is—

1. The battery-case, when constructed in sections  $A B$ , in the manner as and for the purpose substantially as set forth.
2. The special manner of connecting the porous cups to the caps of cylinders, by means of the shoulder  $c'$ , metallic screw-collar or ring  $c$ , and cap  $S$ , in the manner substantially as described.
3. The arrangement of the helices  $T T'$ , surrounding the cylinders  $D E$ , and enclosing circular magnets  $V$ , when said magnets are so arranged that they may be raised or lowered within said helices by an adjusting-screw,  $x$ , for the purpose and in the manner described.
4. A case, constructed of metal or of any other suitable material, enclosing the prime and induction-coils  $T T'$  and  $m' m''$ , for the purpose specified.
5. The foot-plates  $B'$ , provided with the heel  $R'$ , and adjustable toe-cap  $C'$ , as arranged in combination with the battery-case, in the manner as and for the purpose set forth.

HERMAN FRITZ.

Witnesses:

J. H. BURRIDGE,  
FRANK S. ALDEN.